

W. v. d. Haak

COSSOR

INDUSTRIAL OSCILLOGRAPH

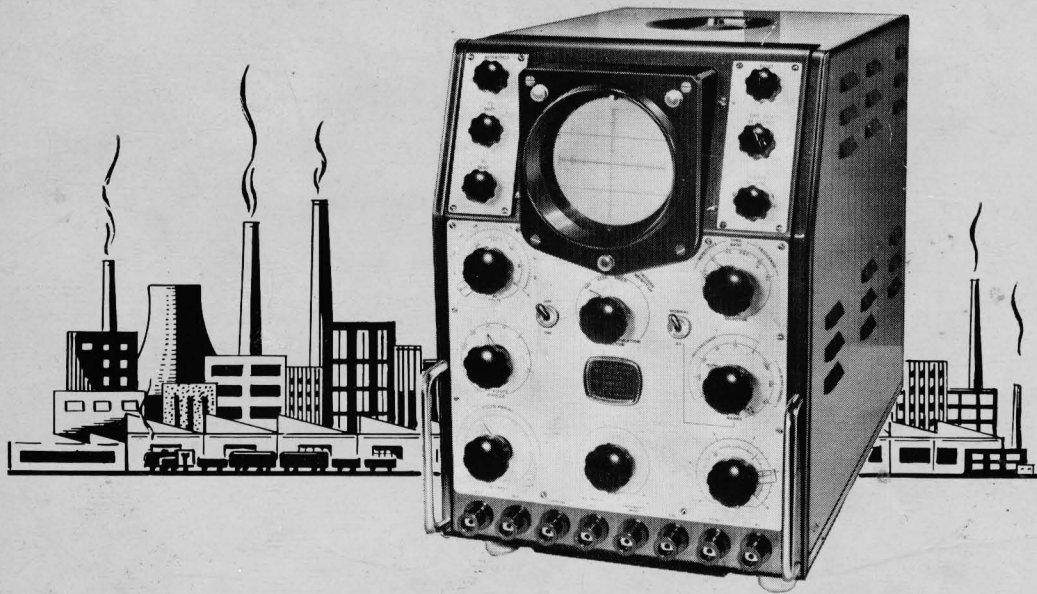

Model 1049 Mk IV

Operating and Servicing

COSSOR

INDUSTRIAL OSCILLOGRAPH

Model 1049 Mk IV

Operating and Servicing

CONTINUOUS DEVELOPMENT MAY RESULT IN MINOR CHANGES TO DESIGN

COSSOR INSTRUMENTS LIMITED

The Instrument Company of the Cossor Group

COSSOR HOUSE · HIGHBURY GROVE · LONDON, N.5 · ENGLAND

Telephone: CAnonbury 1234 (15 lines)
Telegrams: Cossor, Norphone, London
INST.P.19/2/62/5

Cables: Cossor, London, N.5
Codes: "Bentley's Second"
Printed in England

*The Reference Number of this publication is **INST.P.19.***

CONTENTS

	<i>Page</i>
INTRODUCTION	1
SPECIFICATION	2
OPERATING THE OSCILLOGRAPH	4
Power Supply	4
Replacement of Fuses and Valves	4
Brightness and Focus	4
Graticule	4
Raising Member	4
Viewing Hood	5
Voltage Measurement	5
A1 Amplifier	5
A2 Amplifier	5
Time-base	6
Range Selection	6
Selection of Trigger or Sync	6
Time Measurement	6
X5 Scale	7
Intensity Modulation	7
Direct Connection to CRT Plate	7
Selection of 2 kV or 4 kV	8
Beam Brightness Adjustment	8
CIRCUIT DESCRIPTION	9
Cathode-ray Tube	9
A1 Amplifier	9
A2 Amplifier	10
Time-base	11
General	11
Repetitive	11
Triggered	13
Intensity Modulation	14
Power Supplies	15
General	15
+ve 650 V H.T. Circuit	15
2 kV and 4 kV E.H.T. Circuit	16
Heater Circuits	16

CONTENTS

	<i>Page</i>
SERVICING	17
Removing the Instrument Case and Bottom Cover	17
650 V Stabilized Supply	17
E.H.T. Supply	17
Setting-up the A1 Amplifier	18
Grid Current	18
D.C. Level	18
Heater Compensation	18
A1 Volts Calibration	18
Square-wave Response, H.F.	18
Frequency Response	19
Setting-up the A2 Amplifier	19
Sensitivity	19
Square-wave response, H.F.	19
Frequency Response	22
Panel Light	22
Setting-up the Time-base	22
Repetitive	22
Triggered	22
Time Scale Calibration	23
Sync Checks	23
Trigger Checks	24
Trigger Delay	24
Setting-up the Intensity Modulation	24
Calibration Voltage	25
Beam Brightness Equalizer	25
VOLTAGE READINGS	26
CIRCUIT COMPONENTS	34
MECHANICAL PARTS	41
ACCESSORIES	43
SPARES AND SERVICE	44

ILLUSTRATIONS

	Page
Fig. 1 <i>CRT with Beam Brightness Equalizer</i>	8
Fig. 2 <i>Response Curve for A1 Amplifier</i>	10
Fig. 3 <i>Response Curve for A2 Amplifier</i>	11
Fig. 4 <i>Simplified Repetitive Time-base Circuit</i>	12
Fig. 5 <i>Simplified Triggered Time-base Circuit</i>	13
Fig. 6 <i>Simplified H.T. Circuit</i>	15
Fig. 7 <i>Bottom View</i>	31
Fig. 8 <i>Left-hand View</i>	32
Fig. 9 <i>Right-hand View</i>	33
 <i>Circuit Diagram</i>	 20 and 21
 <i>Circuit Diagram (detachable)</i>	

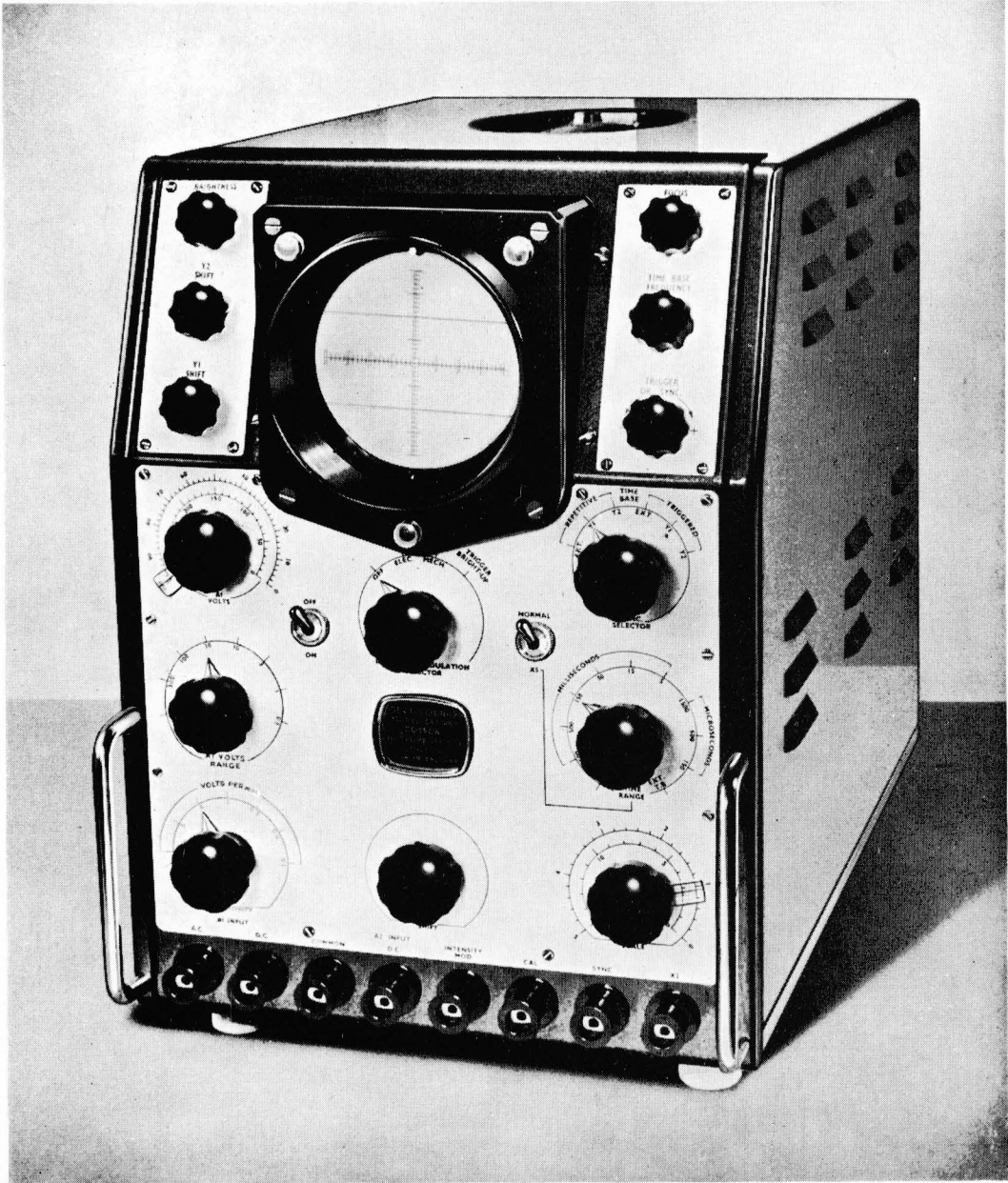

INTRODUCTION

Oscillograph Model 1049 has established itself as an instrument for use in the fields of Servo-control, Electrical Engineering, Vibration Analysis, Electro-medical Instrumentation and many other industries. The Mark IV version incorporates eighteen time-base ranges and a facility for trigger bright-up which enables greatly improved quality of photographic recording to be achieved in the single-stroke mode of operation.

The two d.c. amplifiers have a wide frequency response and are pulse corrected. Triggered or repetitive operation of the time-base is available and the scan may be synchronized from either of the amplifiers or externally. Duration of the scan is variable over a wide range. Two methods of external intensity modulation are provided.

Links enable an E.H.T. voltage of twice the normal value to be used for high writing speeds and photographic work. Stabilized H.T. and E.H.T. potentials are provided and the A1 amplifier is compensated for variations in heater voltage.

Spring-loaded terminals permit quick connection and disconnection of leads and the insertion of small clip connectors or 4 mm continental plugs into their concentric sockets. Model 1049 Mk IV is hammer finished in grey enamel with maroon fittings and polished chromium handles.

SPECIFICATION

Cathode-ray Tube	Cossor 4 in. (10 cm) split-beam, type 89J, with blue fluorescence, operating at 2 kV (a3) or 4 kV. Y sensitivity direct to plates 3 V/mm (0.33 mm/V). X sensitivity direct to plates 2.6 V/mm (0.38 mm/V). Sensitivities will be 6 V/mm and 5.2 V/mm when 4 kV is employed. Direct connections from X and Y plates, E (chassis) and COMMON terminals are available at the side of the instrument.
A1 Amplifier	Maximum sensitivity 33 mV/cm. Five valves. Frequency-compensated input attenuator. Frequency response: d.c. to 200 kc/s at 30 per cent down. Maximum rise-time: 2 μ sec. Maximum overshoot: 5 per cent on attenuated ranges. Maximum input: 1000 V d.c. or peak a.c. Maximum output: full screen up to 90 kc/s, 2 cm at 400 kc/s. When INPUT a.c. terminal is used, there is a reduction of gain of less than 10 per cent at 50 c/s relative to 1000 c/s. Input impedance: 0.5 M Ω to 1.5 M Ω , 10 pF to 70 pF. Directly calibrated voltage scale. Heater supply variations compensated for ± 10 per cent change in mains voltage.
A2 Amplifier	Maximum sensitivity 1 V/cm. Two valves. Frequency-compensated input attenuator. Frequency response: d.c. to 400 kc/s at 30 per cent down. Maximum rise-time: 1 μ sec. Maximum overshoot: 5 per cent on attenuated ranges. Maximum input: 1000 V d.c. or peak a.c. Maximum output: full screen up to 180 kc/s, 2 cm at 800 kc/s. Input impedance: 0.5 M Ω to 5 M Ω , 10 pF to 50 pF. Range switch scaled in deflection sensitivities from 0.1 V/mm to 10 V/mm. Directly calibrated with separate zero adjustment. Measurement accuracy ± 10 per cent.
Time-base	Repetitive or Triggered operation. Directly calibrated time scale with separate zero adjustment. Measurement accuracy ± 10 per cent. Eighteen ranges from 150 μ sec to 7.5 sec. Maximum time-base start time on 150 μ sec range with maximum trigger sensitivity (+ve or -ve) is 1 μ sec. Time scale can be extended by a factor of 5 on each setting of the Time Range switch, by operation of switch marked Normal/X5.

Trigger and Synchronization	<p>Input impedance 3 MΩ, 30 pF.</p> <p>A six-position switch selects External Repetitive/Triggered or Internal Repetitive/Triggered from A1 or A2 output signals.</p> <p>Continuously variable Trigger or Sync amplitude control, positive or negative.</p>																
	Sensitivity	<table border="0" style="margin-left: 20px;"> <tr> <td style="font-size: 3em; vertical-align: middle;">{</td> <td style="vertical-align: middle;">EXT</td> <td style="vertical-align: middle;">{</td> <td style="padding-left: 10px;">10 V peak-to-peak above 20 c/s.</td> </tr> <tr> <td></td> <td></td> <td></td> <td style="padding-left: 10px;">20 V peak-to-peak from 2–20 c/s.</td> </tr> <tr> <td style="font-size: 3em; vertical-align: middle;">{</td> <td style="vertical-align: middle;">Y1, Y2</td> <td style="vertical-align: middle;">{</td> <td style="padding-left: 10px;">1 cm deflection above 20 c/s.</td> </tr> <tr> <td></td> <td></td> <td></td> <td style="padding-left: 10px;">2 cm deflection from 2–20 c/s.</td> </tr> </table>	{	EXT	{	10 V peak-to-peak above 20 c/s.				20 V peak-to-peak from 2–20 c/s.	{	Y1, Y2	{	1 cm deflection above 20 c/s.				2 cm deflection from 2–20 c/s.
{	EXT	{	10 V peak-to-peak above 20 c/s.															
			20 V peak-to-peak from 2–20 c/s.															
{	Y1, Y2	{	1 cm deflection above 20 c/s.															
			2 cm deflection from 2–20 c/s.															
Test Waveform Voltage	50 V peak-to-peak (nominal) between CAL and COMMON terminals.																
Intensity Modulation	<p>Controlled by a four-position switch:</p> <p>OFF.</p> <p>EXT ELECTRICAL: can be used to cut off the beam by applying a negative voltage to the INTENSITY MOD terminal. A 7 V r.m.s. signal will switch the beams on and off at frequencies up to 100 kc/s with the CRT operating on 2 kV or 4 kV.</p> <p>EXT MECHANICAL: enabling beam to be cut off by shorting INTENSITY MOD and COMMON terminals.</p> <p>TRIGGER BRIGHT-UP: cuts off the beams while stationary. When the time-base is triggered, the traces appear immediately. Operated in conjunction with the BRIGHTNESS control.</p>																
Power Supply	<p>Mains: 200 V to 215 V, 216 V to 234 V and 235 V to 255 V for standard model.</p> <p>105 V to 115 V and 120 V to 130 V for low-voltage model.</p> <p>Frequency: 50 c/s to 100 c/s.</p> <p>Consumption: 180 W.</p>																
Size and Weight	<table border="0" style="margin-left: 20px;"> <tr> <td style="padding-right: 20px;">Height</td> <td style="padding-right: 20px;">16½ in.</td> <td>(41.9 cm).</td> </tr> <tr> <td>Depth</td> <td>21¾ in.</td> <td>(55.3 cm).</td> </tr> <tr> <td>Width</td> <td>12 in.</td> <td>(30.5 cm).</td> </tr> <tr> <td>Weight</td> <td>77 lb</td> <td>(35.0 kg).</td> </tr> </table>	Height	16½ in.	(41.9 cm).	Depth	21¾ in.	(55.3 cm).	Width	12 in.	(30.5 cm).	Weight	77 lb	(35.0 kg).				
Height	16½ in.	(41.9 cm).																
Depth	21¾ in.	(55.3 cm).																
Width	12 in.	(30.5 cm).																
Weight	77 lb	(35.0 kg).																

OPERATING THE OSCILLOGRAPH

Caution: The instrument will not operate and may suffer serious damage if connected to a d.c. supply or to a supply of a frequency less than 50 c/s.

Do not touch any part of the circuit while the mains supply is connected. The mains fuses are in the unswitched side of the mains and will be live when the mains supply is connected, even though the instrument is switched off.

POWER SUPPLY

Ensure that the mains selector, accessible by dropping the sliding panel at the rear of the instrument, is set to the range covering the voltage of the supply from which the instrument is to be operated.

Connect the cable lead to a suitable plug and insert this plug into a mains power socket. Move the On/Off switch to the ON position.

REPLACEMENT OF FUSES AND VALVES

If a fuse requires replacing, first remove the instrument power plug from the mains supply socket.

Whenever a valve is replaced, the setting-up procedure for the relevant circuit must be carried out as described in the Servicing section of this handbook.

BRIGHTNESS AND FOCUS

Adjust the BRIGHTNESS and FOCUS controls to give suitable brightness and optimum definition.

GRATICULE

To rotate the graticule, grip the small pin located near the periphery and apply a turning movement. Position the graticule so that the two plain lines are horizontal and parallel to the trace on the CRT.

RAISING MEMBER

Use the adjustable raising member under the front of the instrument, as required, to provide a convenient viewing angle. To bring the raising member into use, grip one of the chromium handles and lift the front of the instrument. Release the raising member from its two spring clips and pull it fully forward.

Note: The raising member can be used to advantage when the instrument is operated at low eye-level in order to obtain better reading accuracy on the graticule.

VIEWING HOOD

The plastic viewing hood, held in position by four screws, serves to locate the graticule and to shield the tube face from unwanted illumination.

VOLTAGE MEASUREMENT

Caution: The input to the A1 or A2 amplifier must not exceed 1000 V d.c. or peak-to-peak a.c.

A1 Amplifier

Use the A1 INPUT d.c. or a.c. terminal.

Put the A1 Volts Range switch to a position such that the waveform to be measured is between 1 cm and 5 cm amplitude.

Set the cursor on the A1 VOLTS scale to zero.

Turn the Y1 SHIFT control to position the waveform (or portion of it) to be measured so that its base is coincident with the centre horizontal line of the graticule or other convenient index line.

Move the cursor so that the top of the waveform (or portion of it) is brought down to the horizontal line or other index line chosen.

If the A1 Volts Range switch is positioned at 1 V or a multiple of ten of this figure, read the voltage direct from the **outer** scale of the A1 VOLTS control, placing the decimal point according to the range setting.

If the A1 Volts Range switch is positioned at 0.3 V or a multiple of ten of this figure, read the voltage direct from the **inner** scale of the A1 VOLTS control, placing the decimal point according to the range setting.

A2 Amplifier

N.B. The input attenuator provides a d.c. path to earth and, if this is likely to cause interference to the apparatus being tested, an external capacitor must be used.

Use the A2 INPUT d.c. terminal. Position the waveform (or portion of it) to be measured as described for the A1 amplifier but using the A2 Volts Range switch, Y2 SHIFT and A2 SENSITIVITY controls.

To determine the voltage of a signal, or part thereof, measure its amplitude in millimetres with the graticule and multiply by the factor indicated by the A2 SENSITIVITY control.

If the 4 kV E.H.T. supply is in use, multiply this factor by 2 because the deflection sensitivity of the CRT is inversely proportional to its anode voltage.

TIME-BASE

Range Selection

For general use, choose a Time Range so that the input waveform appearing on the screen is between 2 and 6 cycles.

Selection of Trigger or Sync

Use the Sync Selector switch to trigger or synchronize the time-base from either amplifier or from an external signal applied between the SYNC and COMMON terminals.

Select the polarity of the synchronizing triggering pulse applied to the time-base by turning the TRIGGER or SYNC control as required.

Note: The + and - symbols are read when signals are applied to the Sync terminal. Selection of Sync or Trigger from either amplifier will be of reversed polarity to signals applied to Sync terminal.

To find the centre zero position of the TRIGGER or SYNC control, rotate the knob until the engraved dot is uppermost.

Time Measurement

If the time-base is in the repetitive condition, resolve the trace into an almost stationary waveform by selection of the appropriate scanning speed with the Time Range Switch and TIME-BASE FREQUENCY control. Lock the trace by minimum rotation of the TRIGGER or SYNC control.

Note: The repetition rate of the scan is adjusted by the TIME-BASE FREQUENCY control which does not vary the velocity of the spot. Therefore, maintaining a constant spot velocity with a varying repetition rate will involve a change in sweep amplitude and the trace length is, for a given Time Range setting, inversely proportional to the repetition rate of the time-base.

When the time-base deflection is locked to the signal, set the TIME SCALE control to zero and use the X SHIFT control to position the point of the trace from which measurement is required to the vertical datum line on the graticule.

Rotate the TIME SCALE control to move the trace through the 'distance' to be measured and read the Time interval direct from the control dial, the **outer** scale being used on the 500 msec, 50 msec, 5 msec and 500 μ sec time-base ranges and the **inner** scale on other ranges.

X5 Scale

When a greater time range is required, move the Normal/X5 switch to the X5 position, giving scales of 750 μ sec, 2.5 msec, 7.5 msec, 25 msec, 75 msec, 250 msec, 750 msec, 2.5 sec and 7.5 sec. For these time ranges, divide the scale reading by two and place the decimal point appropriately for the range in use.

INTENSITY MODULATION

Caution: When operating in the triggered mode, the Intensity Modulation Selector should be set to the TRIGGER BRIGHT-UP position so that, if the triggering signal ceases, then the beams will be cut off automatically, thus protecting the CRT screen.

The Intensity Modulation Selector has four positions:

OFF. All modulation systems are inoperative and the traces are displayed at an intensity determined only by the BRIGHTNESS control.

ELEC. In this position, the beams may be switched off by applying a negative d.c. pulse or switched on and off by applying an alternating voltage to the INTENSITY MOD terminal. A 7 V r.m.s. signal will switch the beams at rates up to 100 kc/s, the return or positive connection being made to COMMON. The control is practically instantaneous in action and the effect is maintained as long as the voltage remains applied. However, there is no direct connection from this terminal to the CRT grid. The switching potential affects the operation of a high-frequency oscillator circuit which, in turn, is responsible for the tube bias excursions. Hence, the possibility of a dangerous high-voltage shock from this point is removed.

MECH. The beams are switched off for the duration of a short circuit made between the INTENSITY MOD and COMMON terminals which impose a resistive electrical load upon the external switch or contactor of less than 2 mA at 70 V.

TRIGGER BRIGHT-UP. This facility is provided for use with the time-base operating in the triggered mode and will cause the stationary beams to be cut off. A slight readjustment of the BRIGHTNESS control may be necessary to obtain complete black-out. When the sweep is triggered, the beams immediately operate at normal brightness during the forward stroke and are blacked out during fly-back and until the next trigger.

DIRECT CONNECTION TO CRT PLATE

Caution: Do not touch any link or terminal when the power is applied to the instrument. Switch off the power supply and allow not less than 30 seconds to elapse before touching the links.

Terminals are provided, behind the side panel, to allow for direct connection of the signal to the deflector plates. Each terminal has three sockets beside it, the centre socket being connected to the plates, the right-hand sockets to the time-base and amplifiers, and

the left-hand sockets to the four terminals. To apply an external signal to any plate the plugs must be transposed to connect the centre to the left-hand socket.

Normally, the chassis and case of the instrument, connected to the E (CHASSIS) terminal on the side panel, are linked to the COMMON terminal by the wire link provided. When direct connection to the CRT plates is required, operate the plates at or near the potential of the third anode, that is, 325 V above COMMON. Positive or negative inputs within 150 V of earth potential can be applied by linking E (CHASSIS) to TUBE ANODE for the return path to external circuits, COMMON being left disconnected because it will become 325 V negative with respect to the instrument case.

SELECTION of 2 kV or 4 kV

Caution: The instrument must be switched OFF for at least two minutes before this adjustment is made.

To change from the normal 2 kV to 4 kV operation, transpose, to the right, the three plugs located in panel behind the rear door in the instrument case.

BEAM BRIGHTNESS ADJUSTMENT

If it is desired to correct for lowered beam brightness resulting from a greater signal excursion on one beam, carry out the procedure for this given on page 25.

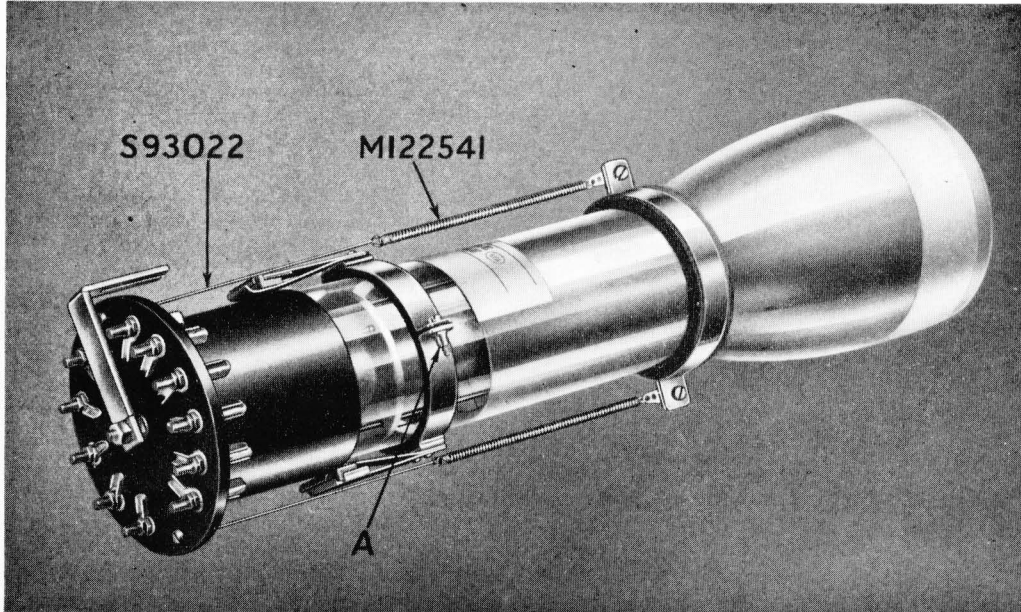

Fig. 1 CRT with Beam Brightness Equalizer

CIRCUIT DESCRIPTION

CATHODE-RAY TUBE

A split-beam tube V23 is used with the E.H.T. at 2 kV. For photographic purposes, 4 kV is available and is particularly advantageous for high writing speeds.

The CRT is fitted with a magnetic device for adjusting beam brightness and is set correctly at the Factory for equality of beam current when operating at 2 kV. This device can also be used to equalize the brightness of each beam when the signals on the two channels result in a much higher writing speed on one channel than on the other. In such instances, the magnet may be re-positioned to increase the brilliance of the trace that has the higher writing speed.

Two brass, felt-lined clamping bands, each with a compensating magnet in a holder extending from the band, are positioned round the neck of the CRT (see Fig. 1), with the magnet pointing towards its base, and positioned radially so that one of them lies between the CRT base contacts marked A2 and Y2.

A1 AMPLIFIER

The input attenuator assembly is contained inside a screening box with external connections made by low-capacity screened cable. Resistors and capacitors for the fixed steps are of 2 per cent tolerance.

For the attenuator, H.F. compensation is controlled by the trimmer C31 and—for the amplifier—by C33 in the negative feedback loop. The amplifier includes valves V9–V13 fed from a common centre-tapped heater supply, V9 and V10 being of the same type.

The screen supply for V9 is derived from the anode voltage of V10, so that any fall in cathode emission caused by a drop in the heater supply will raise the potential of V10 anode and V9 screen, producing a compensating change in the working conditions of V9. Potentiometers, P11 and P12, set the initial voltage at V9 screen and control the degree of compensation.

After the first stage of amplification, the signals at the anode of V9 are superimposed on the d.c. level set by the Y1 SHIFT and A1 VOLTS controls, calibration for A1 VOLTS control being adjusted by P13. Signal and shift voltages are directly coupled from the anode of V9 to the grid of triode V11, a cathode-follower which, in turn, is directly coupled to the grid of V12.

The cathode-follower, having a lower input capacity than V12, has less shunting on the anode load of V9 at high frequencies. To obviate loss of gain in V12 caused by negative feedback in its cathode circuit, that valve is operated in conjunction with V13 to form a long-tail pair. The output from V13 feeds the trigger and synchronizing circuits while V12 anode is directly connected to Y1. Potentiometer P14 adjusts the d.c. potential on Y1 under no-signal conditions. Response curve for this amplifier is given at Fig. 2 (page 10).

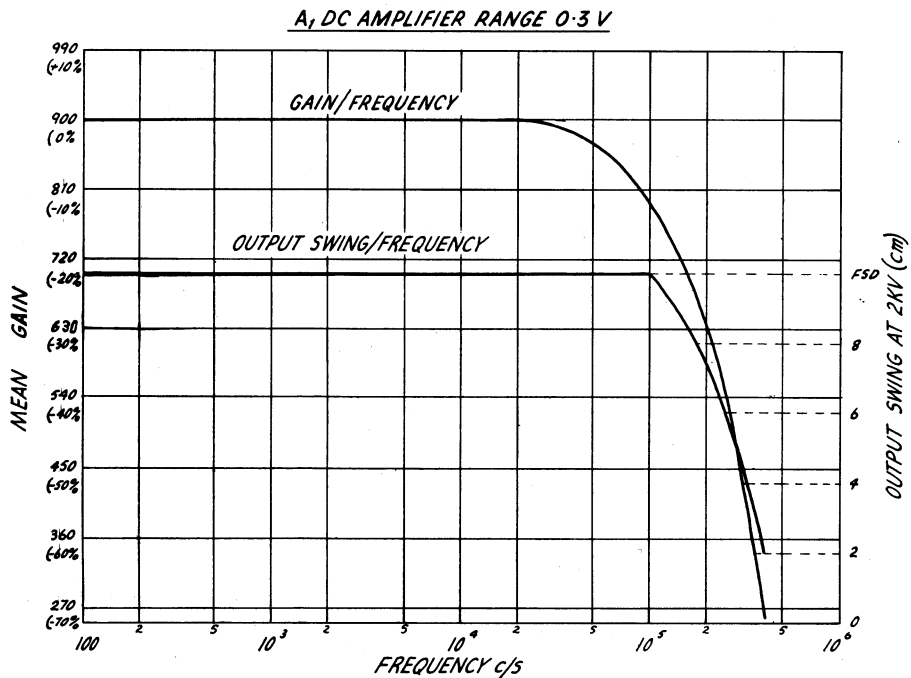

Fig. 2 Response Curve for A1 Amplifier

A2 AMPLIFIER

The frequency-compensated input attenuator is controlled by the A2 Sensitivity switch, S13, S14. As in the A1 amplifier, the attenuator has resistors and capacitors of 2 per cent tolerance for the fixed steps. Pre-set capacitor C58 is adjusted to standardize the input capacity of the amplifier valve V21.

The gain of V21 is pre-set by P23 which controls the amount of cathode feedback. Frequency compensation is achieved by adjustment of C65, the pre-set control which reduces the cathode feedback at higher frequencies. The tetrode V22, connected as a cathode-follower, supplies to the anode of V21 an H.T. potential which may be varied by P25 to provide Y2 shift control without affecting the gain of V21.

After amplification, signals are fed to the synchronizing and triggering circuits and direct to the Y2 plate.

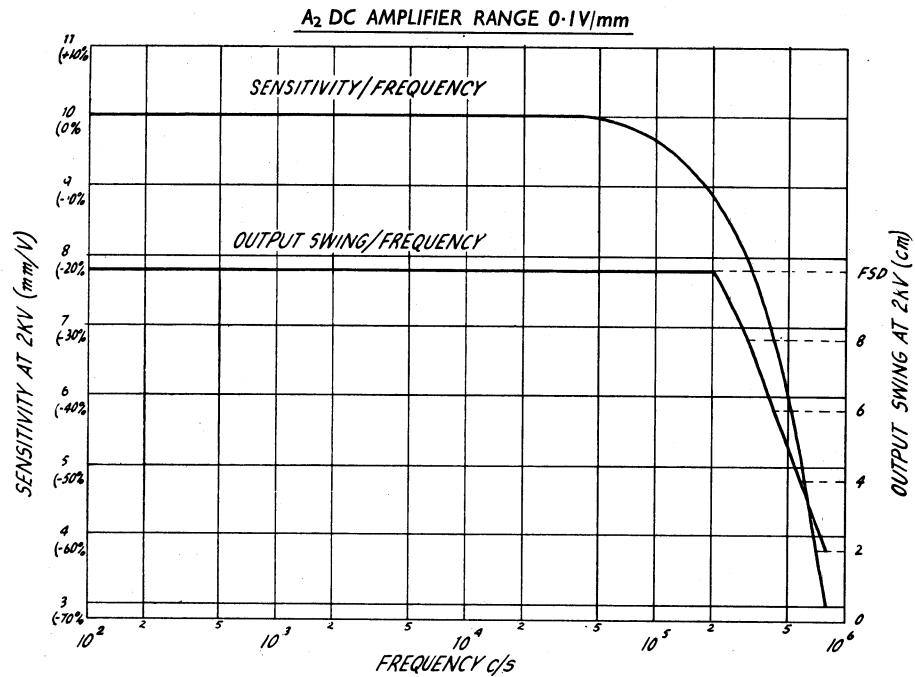

Fig. 3 Response Curve for A₂ Amplifier

TIME-BASE

General

Four valves are associated with the time-base circuits. Valve V5 is a concertina-type phase splitter and trigger/sync amplifier and V6 governs the time-base frequency. The saw-tooth waveform is produced by V7 and V8, their mode of operation differing for repetitive and triggered time-bases.

Repetitive

A simplified diagram of this circuit is shown in Fig. 4. The Miller valve is V8 while V7 forms its anode load and provides the suppressor switching waveform. At an instant during the scan (forward stroke), V8 is conducting and C11 (or whichever capacitor is selected by S4) will be discharging through R29 and V8 anode until the bottom bend of the I_a/V_a characteristic of V8 is reached. When this occurs, the discharge ceases and reduces the grid bias developed across R29 for V7. The fall of anode voltage of V7 through

R35 causes a fall at the suppressor of V8 which cuts off anode current in that valve. There is then no bias to V7 and the cathode current of that valve will flow into C11 and to COMMON via the grid/cathode path of V8 which acts as a diode. Thus, the fly-back stroke, which is very fast because of the low output impedance at the cathode of V7, is initiated. The high anode current in V7 at this instant increases the negative bias on the suppressor of V8 to a high value initially but, as the charging current decreases, this high bias falls also.

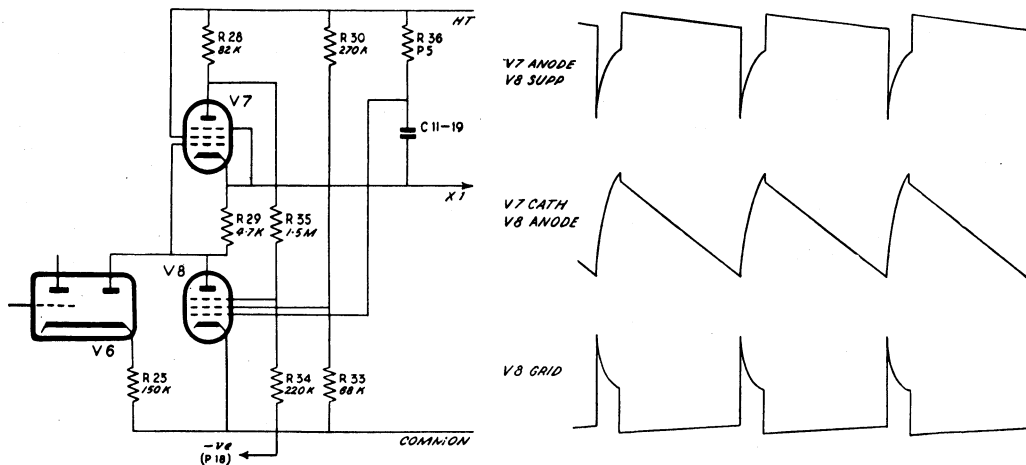

Fig. 4 Simplified Repetitive Time-base Circuit

When the anode of V8 attains a potential equal to that existing at the cathode of V6, the diode sections of V6 conduct and prevent a further rise in the anode voltage of V8. The capacitor charging current ceases and bias is applied to V7 by the diode current flowing through R29, that is, the anode current of V7 is reduced suddenly.

The resulting increase in the anode potential of V7 brings the suppressor of V8 up to cathode potential, allowing that valve to conduct anode current and so reduces the potentials at the anode of V8 and cathode of V7, rendering V6 diodes inoperative. Normal Miller run-down takes place, capacitor C11 discharging through R29 and the anode of V8 to produce a linear fall of voltage at the anode of V8 and cathode of V7. The time-base output is taken to X1 from the cathode of V7.

The point at which the diodes of V6 conduct is determined by the cathode voltage of that valve which, in turn, is governed by the instantaneous grid voltage of its triode section. The d.c. level of the grid is set by the TIME BASE FREQUENCY control and any synchronizing pulses from V5 are superimposed upon this level. Typical voltage waveforms for a repetitive time-base are shown in Fig. 4.

Triggered

A simplified diagram of this circuit is shown in Fig. 5. Valve V8 is operated as a screen-coupled phantastron with V7 as its anode load. In the stable state, the anode current of V8 is cut off by a negative suppressor voltage, its grid is at cathode potential approximately and is taking grid current via the timing resistors R36 and P5, while heavy screen current keeps the screen voltage down to about +ve 20 V. The anode potential of V8 is held by the diodes of V6 at the cathode potential of that valve, the diode current passing through V7.

To initiate the run-down, a negative-going signal must be received from the trigger amplifier. When this occurs, the cathode potential of V6 falls and with it, via V6 diodes, the anode of V8 and cathode of V7. This fall in potential is coupled by C11 (or whichever capacitor is selected by S4) to the grid of V8, reducing the screen current. The rise in screen potential, through R37, C70 makes the suppressor less negative. If the triggering signal is of sufficient amplitude, this rise in suppressor potential will permit anode current to flow. Thus, a further reduction of screen current gives an increased potential to the screen and suppressor, the cumulative action resulting in the anode of V8 being fully conductive.

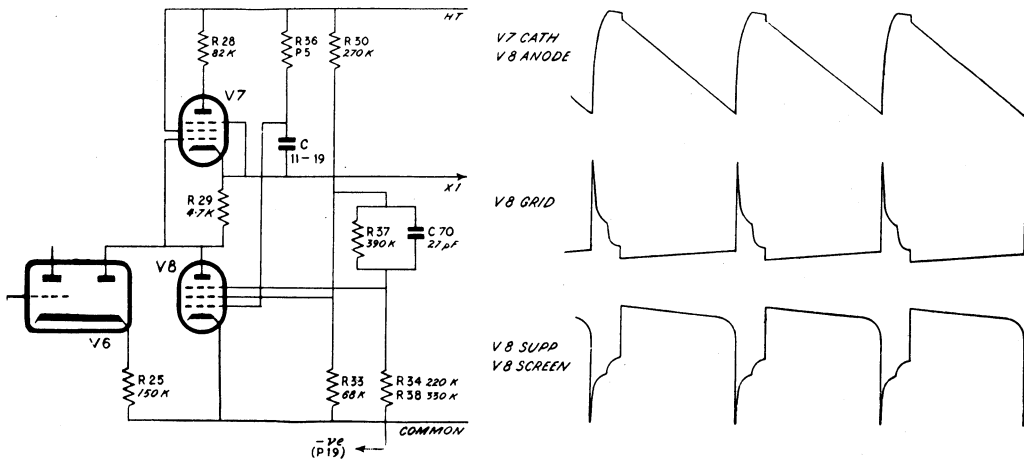

Fig. 5 Simplified Triggered Time-base Circuit

During this switching action, the anode voltage of V8 drops sufficiently to cut off the diodes of V6. Since the grid of V8 is in the Miller operating condition, having been driven there by the trigger signal, and the anode of V8 is conducting, the linear run-down begins and continues until the anode of V8 'bottoms', when discharge current of C11 will cease. The screen current of V8 rises rapidly (as the grid voltage leaks away) so that the suppressor cuts off the anode current of V8. Valve V7 then has no grid/cathode bias and recharges C11 rapidly through the diode formed by the grid/cathode path of V8. The rising potential at the anode of V8 is limited by the diodes of V6 conducting to complete the fly-back; the circuit is then ready for re-triggering. Typical voltage waveforms are shown above.

INTENSITY MODULATION

The modulating voltages on the grid of the CRT are derived from the balanced detector valve V18, which is mounted on a small sub-chassis because it operates at almost the full negative E.H.T. voltage. Valve V18 is coupled via the low-value, high-voltage capacitor C43 to a Hartley oscillator V19. Consequently, the CRT beam is cut off while this oscillator is functioning. The second half of V19 and C49 provide decoupling for the oscillator cathode.

The oscillator valve V19 which operates at a frequency of about 4 Mc/s is itself controlled by the bias developed across R107 by the anode current of V20 and is able to function only when the anode current of V20 is cut off.

The anode current of V20 is controlled as described below in accordance with the setting of the four-position Intensity Modulation Selector switch.

OFF. Valve V20 anode conducts, V19 is inoperative and beam current is controlled entirely by the BRIGHTNESS control.

ELEC. The anode current of V20 is controlled by a signal connected between INTENSITY MOD and COMMON terminals: a negative d.c. or negative pulse of above 10 V will cut off the anode current of V20, and, hence, the CRT beam current. Alternating inputs above 7 V r.m.s. will cause the beam to be switched at rates up to 100 kc/s and, thus, a suitable external circuit may be employed to provide time calibration.

MECH. At this setting, a short circuit applied by an external switch across the INTENSITY MOD and COMMON terminals cuts off the screen supply to V20 and thus allows V19 to operate and cut off the beam current. The electrical load on an external contactor is resistive and is less than 2 mA at 70 V.

TRIGGER BRIGHT-UP. At this setting, the grid circuit of V20 is connected to a frequency-compensated potential divider between V8 screen and the junction of R89/P18. Potentiometer P24 pre-sets the quiescent bias on V20 grid sufficiently negative to prevent conduction. Thus, the beam is cut off until the time-base is triggered when a positive pulse from the screen circuit of V8 is fed via R32 and C37 to the grid circuit of V20, resulting in the switching on of the CRT beam. This position is intended for use when operating the time-base in the triggered mode and permits photography of transient phenomena without danger of fogging and also protects the CRT screen from possible damage caused by the spots remaining stationary.

Minimum interference with the displayed waveform is assured by this method employed to provide, for example, Time markers by intensity modulation and, for this reason, intensity modulation is preferable to Time markers superimposed as amplitude modulation.

POWER SUPPLIES

General

The instrument is designed to operate from 50 c/s to 100 c/s supplies of 105 V to 130 V or 200 V to 250 V and is stabilized against variations of up to $\pm 10\%$ on the mean voltage for each tapping range, that is, 110 V, 125 V or 207 V, 225 V and 245 V. The return path of all circuits (COMMON) is isolated from the chassis except for a 470 pF capacitor and a removable link on the side panel.

The power load is carried by three transformers; T1 and T3 supply the heater circuits and the third transformer T2 provides the H.T. and E.H.T. potentials and CRT heater supply. To assure maximum reliability, T2, which has a C-core, is oil-filled and no electrolytic capacitors are employed in the oscillograph. Two 3 A fuses are arranged in the primary circuit of the transformers and another, F3, rated at 500 mA, in the high-tension secondary of T2. The fourth fuse F4 is located in the primary circuit of T2 and is rated at 2 A.

+ve 650 V H.T. Circuit

The positive supply for the time-base and amplifiers is obtained from a voltage-doubler system and is electronically stabilized by a circuit incorporating a Metrosil bridge. A simplified diagram of these circuits is shown in Fig. 6.

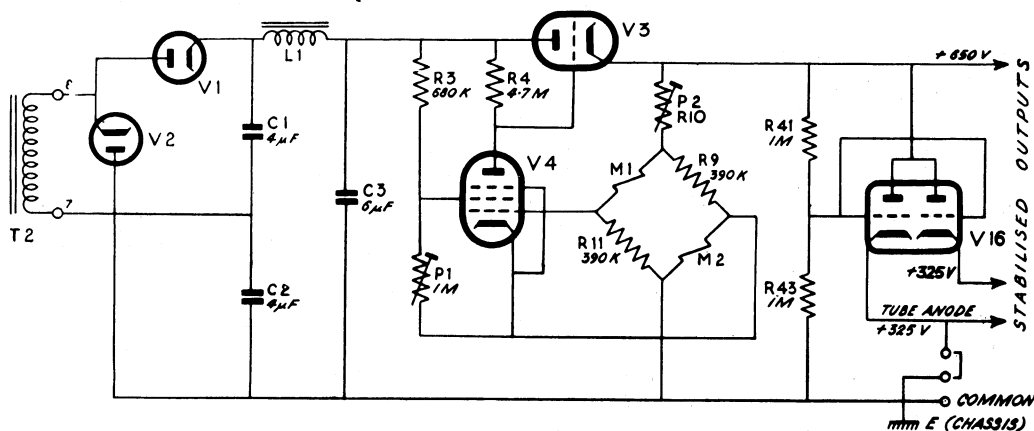

Fig. 6 Simplified H.T. Circuit

By returning the negative terminal of C2 to COMMON, the potentials developed across C1 and C2 become additive and, after smoothing provided by the choke input filter L1, C3, supply 900 V to the stabilizing circuit. A small decrease in the potential

of the 650 V H.T. line will increase the resistance of Metrosils M1 and M2 and, hence, the grid-cathode potential of V4. The rise in voltage of V4 anode is coupled to the control grid of V3 increasing its conductance and so minimizing the change in voltage of the H.T. line.

Additional stabilization and smoothing is provided by feeding the screen grid of V4 with a portion of the voltage at V3 anode. Potentiometer P2 sets the voltage level whilst P1 governs the degree of stabilization.

-ve 2 kV and -ve 4 kV E.H.T. Circuit

This stabilized negative supply for the CRT is obtained from the half-wave rectifier V14 in conjunction with C39. The positive return is through V15 (shunted by R73) and the screen grid of this valve is fed from a potential divider across the stabilized 650 V supply. Stabilization is achieved by feeding the grid of V15 with a portion of the E.H.T. voltage.

Smoothing is obtained by feeding also to the grid of V15 a ripple voltage coupled by C40. Valve V15 operates as a cathode-follower and reduces the ripple to approximately 10 V at 4 kV.

The alternative operating potential of 4 kV has been provided to make possible the high writing speeds necessary for the observation and photography of certain transient phenomena. Transition from the normal 2 kV to the 4 kV operating condition is effected by transposing, to the right, the three plugs located in the panel behind the rear trap-door in the case. The instrument must be switched off before transposing these plugs (see page 8).

With the links positioned for 4 kV operation, the full E.H.T. secondary of T2 is used whereas in the 2 kV position, half of this winding is employed. Voltage adjustment is provided by pre-set controls for both 2 kV and 4 kV operation by variations of bias on V15. In the 2 kV position, potentiometer P17 is used and on the 4 kV position P16.

Heater Circuits

Ten separate heater windings are provided by the three mains transformers.

On T3, tags 27-28 are tied to +ve 650 V and feed V3; tags 30-31 and 32-33 feed the voltage doubler rectifiers V2 and V1 and are tied to their respective cathodes; tags 34-35 feed V4 and are tied to its cathode.

On T2, tags 36-37 feed the CRT and V18 and are tied to the CRT cathode potential; tags 11-12 feed V14 and are connected to its cathode.

On T1, tags 18A-18B supply V22 and are connected to its cathode through R137; tags 16-17 feed V6 and are tied to its cathode through R125; tags 19-20 are connected to +ve 325 V and supply V16, V7, V19; tags 21-22 are centre-tapped to common through R133, R134 and supply V5, V8, V9, V10, V11, V12, V13, V15, V20 and V21.

SERVICING

Caution: Do not touch any part of the circuit while the power supply is connected to the instrument. When the oscillograph is switched off, not less than two minutes must be allowed to elapse before touching any part of the wiring. Some tags of the CRT holder and terminals on the side panels carry very high potentials. Contact with such points is dangerous.

REMOVING THE INSTRUMENT CASE AND BOTTOM COVER

Switch off the oscillograph. Disconnect the instrument power plug from the mains supply.

Remove the four screws which hold the instrument case to the chassis. Grip the rear of the case between the palms of the hands, lift slightly, then retract the case from the guide-channels in the bottom tray.

If the bottom cover hampers adjustments, remove it by taking out four 2 B.A. screws which hold it to the instrument.

650 V STABILIZED SUPPLY

The load stability of the 650 V supply can be checked by drawing an extra 20 mA with resistors (32.5 k Ω , 15 W) from the H.T. coil to COMMON. For this test, the supply to the instrument must be the exact mean voltage of the tapping range in use. The change in potential should not exceed ± 1 V. If it does so, carry out the procedure given below.

Use a Variac and set the voltage applied to the instrument to the mean value of the tapping range used. Adjust P1 and P2 (see Fig. 8) for an H.T. line of 650 V. Vary the applied voltage by ± 10 per cent when the H.T. line should not alter by more than ± 2 V. If 'under-stabilized', reduce the voltage by adjusting P1 and restore it to 650 V by adjusting P2; if 'over-stabilized', increase the voltage by adjusting P1 and restore it to 650 V by adjusting P2.

E.H.T. SUPPLY

With the E.H.T. links set for 2 kV, connect a 1000 V electrostatic meter from the anode (top cap) of V15 to COMMON and adjust P17 (see Fig. 9) for a reading of 550 V. Measure the E.H.T. voltage with a 2 kV electrostatic meter between the anode (top cap) of V14 and COMMON, checking that it is -ve 1650 V ± 100 V.

Apply an audio-frequency voltage between the A2 INPUT and COMMON terminals and adjust its amplitude and/or A2 SENSITIVITY control to obtain a deflection of 6 cm.

Switch off the power to the instrument and change the E.H.T. links to the 4 kV setting. Switch on and adjust P16 (Fig. 9) until a deflection of exactly 3 cm is obtained, checking that the voltage across V15 does not exceed 1000 V.

SETTING UP THE A1 AMPLIFIER

Grid Current

With no connection to the A1 terminals, check that the vertical trace movement does not exceed 2 cm when the A1 Volts Range switch is changed from position 100 to position 0·3.

D.C. Level

Connect an Avometer Model 8 on 1000 V range from the grid of V12 to the grid of V13 (pin 7) and adjust Y1 SHIFT and/or A1 VOLTS until the meter indicates zero on a range not greater than 10 V full scale deflection. Bring the trace to the horizontal centre line, using P14 (see Fig. 8) and maintaining the grid-to-grid voltage at zero by altering the shift controls when necessary. Remove the meter.

Heater Compensation

Reduce the mains input to the instrument by 10 per cent from the mean value of the tapping range in use, note any trace movement and return the mains to the mean value. If the movement was greater than 2 mm and downwards, move P11 (Fig. 8) clockwise and restore the trace to centre line with P12 (Fig. 8).

Re-check and readjust until the trace moves less than 2 mm for a 10 per cent mains change. Repeat the checks with an increase of 10 per cent and, if necessary, make further adjustments to P11 and P12 until the trace remains within ± 2 mm of the centre line throughout the range of ± 10 per cent on the mean mains voltage.

A1 Volts Calibration

Apply a standard 50 c/s input of 5 V ± 3 per cent peak-to-peak between A1 INPUT d.c. and COMMON terminals with the A1 Volts Range set to 10. Adjust P13 (Fig. 8) until the amplitude measured with the A1 VOLTS control is correct. Other ranges should be checked with suitable standard inputs and an accuracy of ± 10 per cent obtained throughout by alterations to P13.

Square-wave Response, H.F.

Set A1 Volts Range to 0·3, Time Range to 150 μ sec and Sync Selector to TRIGGERED Y1. Apply to the A1 INPUT d.c. terminal a 12 kc/s square wave (maximum rise-time 0·2 μ sec) of an amplitude to give a 4 cm deflection. Adjust the TRIGGER or SYNC control

to obtain a steady display with the TIME BASE FREQUENCY control at or near its fully counter-clockwise position and adjust C33 (Fig. 8) until overshoot is not visible.

Turn the A1 Volts Range to 1, increase the input to restore a 4 cm deflection and adjust C31 (Fig. 8) until again the overshoot is zero.

Switch to other ranges in turn with suitable inputs and check that the overshoot or undershoot is never greater than 5 per cent and that the rise-time remains approximately constant. Note which range has the longest rise-time, that is, undershoots most.

Frequency Response

With the A1 Volts Range switch at the setting giving the longest rise-time, apply a sinusoidal input to the A1 d.c. terminal to give a 3 cm deflection at 1 kc/s.

Maintaining this level of input, check that the gain does not fall by more than the percentages given below for the frequencies quoted:

90 kc/s	200 kc/s	300 kc/s	400 kc/s
10%	30%	50%	70%

Using the INPUT a.c. terminal, the gain at 50 c/s should be within 10 per cent of that at 1 kc/s.

SETTING UP THE A2 AMPLIFIER

Sensitivity

Apply a standard input of 5 V \pm 3 per cent peak-to-peak to the A2 and COMMON terminals with the A2 Sensitivity switch at 0.1 V/mm. Adjust P23 (see Fig. 8) to obtain a 50 mm deflection.

Check other ranges with suitable standard inputs and obtain an accuracy of \pm 10 per cent throughout by further adjustments of P23 where necessary.

Square-wave Response, H.F.

With the A2 Sensitivity switch at 0.1 V/mm, apply a 12 kc/s square wave voltage (maximum rise-time 0.2 μ sec) to the input to give a 3 cm trace and adjust C65 (Fig. 8) to the point where the overshoot is not visible.

Change to the 0.2 V/mm range, increase the input to restore a 3 cm display and adjust C58 (Fig. 8) to give zero overshoot.

NOTE:
THIS CIRCUIT SHOWS
WIRING WHEN 200V/250V
TRANSFORMER KA30309
IS USED

CONNECTIONS OF T2
PRIMARY FOR INPUT
SUPPLIES OF 110-125V
ARE SHOWN BELOW
(PT No. KA30310)

TO FUSE START
F4

TO FUSE
F4

TO S9

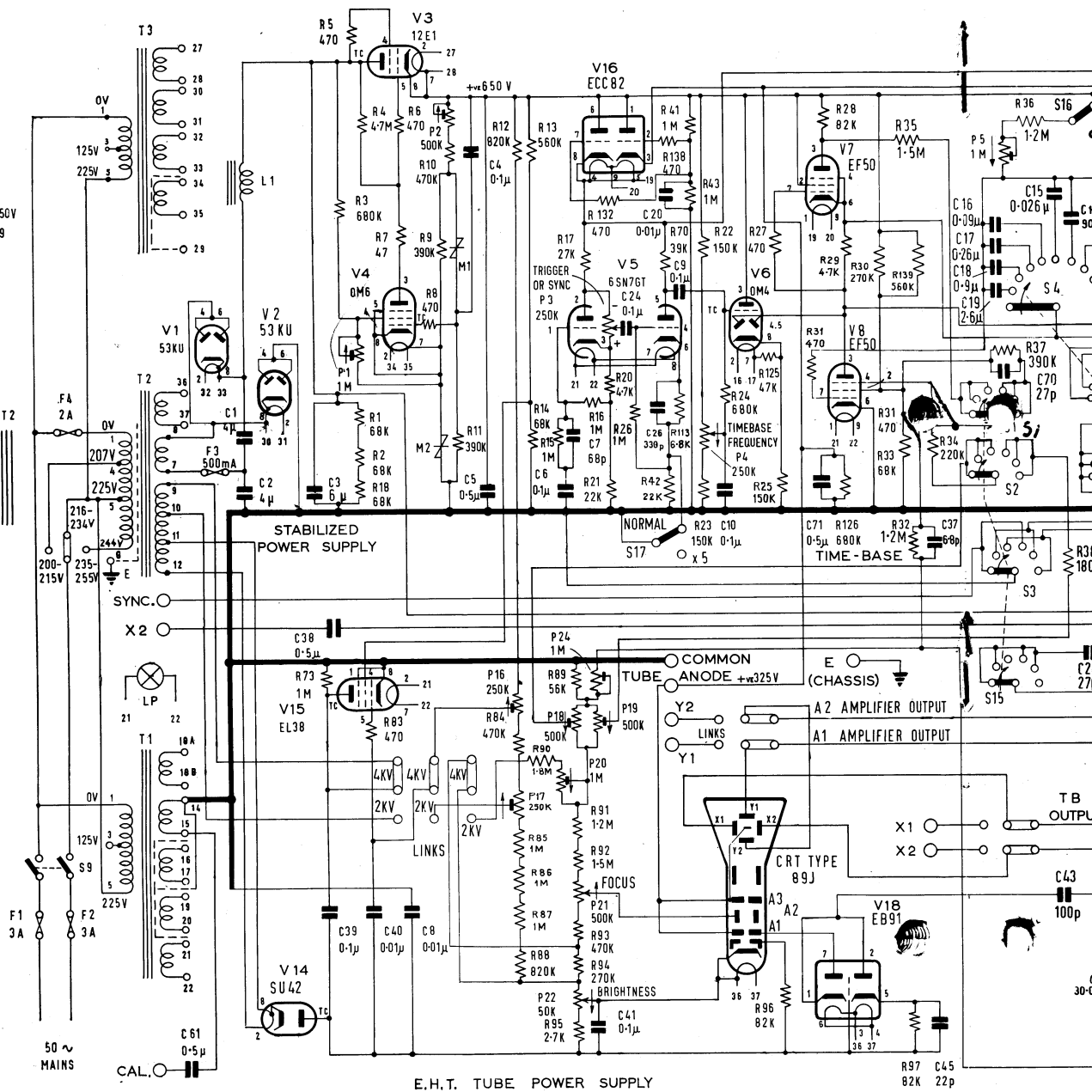

S1 S2 S3 AND S15 GANGED
S4 S5 AND S6 GANGED
S7 AND S8 GANGED
S9
S11 AND S12 GANGED
S13 AND S14 GANGED
S16 AND S17 GANGED

SYNC SELECTOR
TIME RANGE
A1 VOLTS RANGE
MAINS ON/OFF
INTENSITY MOD SELECTOR
A2 SENSITIVITY
TIME SCALE X5

NOTE: 1 ALL SWITCHES ARE SHOWN IN COUNTER-CLOCKWISE POSITION AS VIEWED FROM SPINDLE END
2 METALLIZING PINS OF 0M6 EF50 AND 0M4 VALVES TOGETHER WITH CAN CONNECTIONS ARE ALL CONNECTED TO COMMON. SCREENING CAN FOR EB91 IS NOT CONNECTED
3 A1 ATTENUATOR SCREEN IS CONNECTED TO COMMON NOT 'E' (CHASSIS).
4 CHASSIS MUST CONNECT TO COMMON OR CRT ANODE BY SIDE TERMINAL PANEL ONLY.

COSSOR OSCILLOGRAPH Model 1049 Mk IV

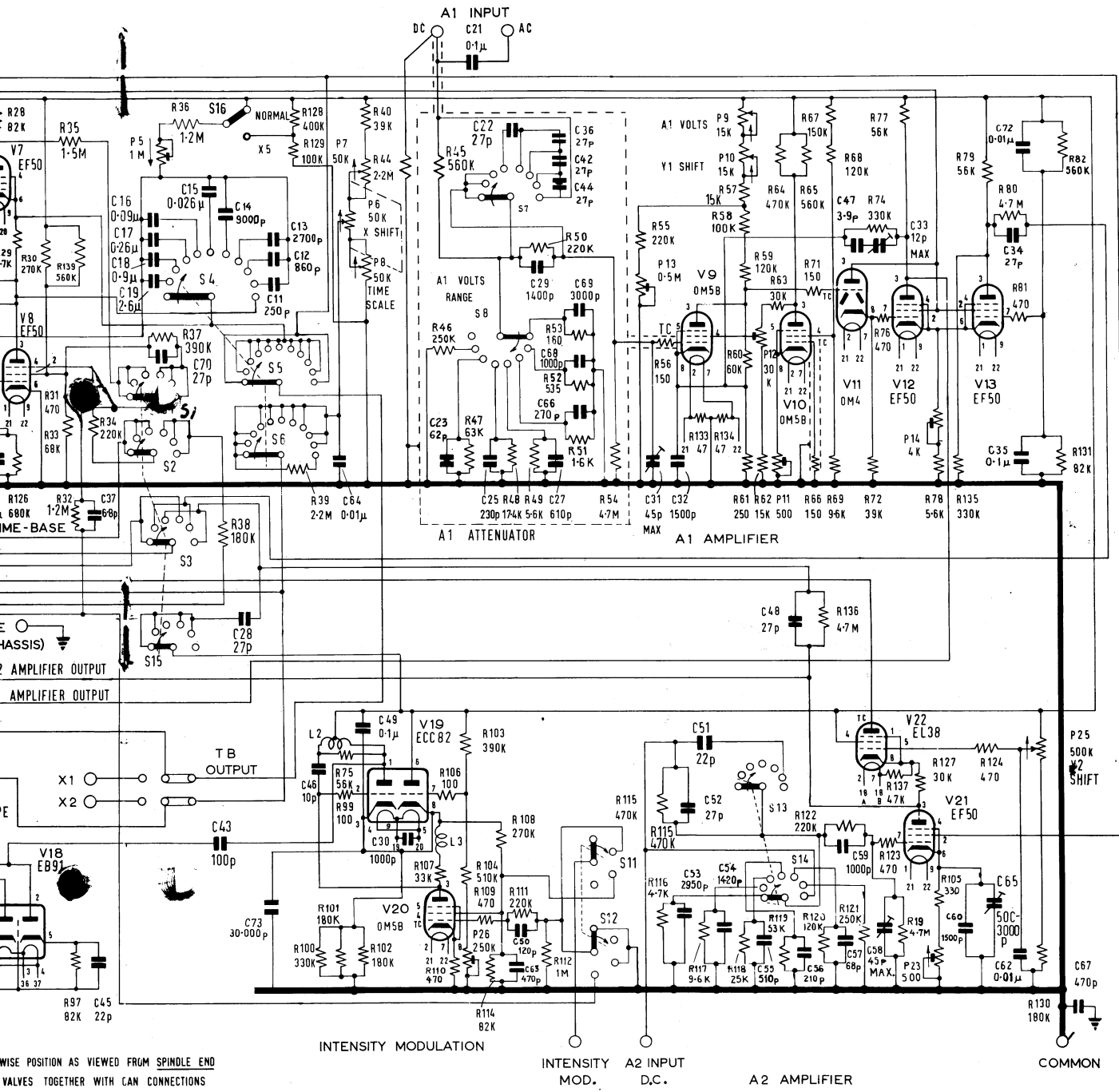

VALVE POSITION AS VIEWED FROM SPINDLE END
 VALVES TOGETHER WITH CAN CONNECTIONS
 G CAN FOR EB91 IS NOT CONNECTED
 'COMMON' NOT 'E' (CHASSIS).
 RT ANODE BY SIDE TERNAL PANEL ONLY.

GRAPH Model 1049 Mk IV — CIRCUIT DIAGRAM

Switch to other ranges in turn and with suitable inputs, check that the overshoot or undershoot is never greater than 5 per cent and that the rise-time remains approximately constant. Note which range has the longest rise-time, that is, undershoots most.

Frequency Response

With the A2 Sensitivity switch on the range giving the longest rise-time, apply a sinusoidal input to A2 to give a 3 cm deflection at 1 kc/s. Maintaining this level of input, check that the gain does not fall by more than the percentages given below for the quoted frequencies:

180 kc/s	400 kc/s	600 kc/s	800 kc/s
10%	30%	50%	70%

PANEL LIGHT

To remove the 6 V bulb which illuminates the name-plate, detach the raising member by squeezing the two end-pieces inwards; remove the four screws adjacent to the rubber feet and take off the base-plate. Do not remove the case.

Withdraw the bulb in its rubber moulding by making a quarter-turn to bring the two lugs on the moulding into line with corresponding cut-outs in the metal box.

SETTING UP THE TIME-BASE

Repetitive

Set the E.H.T. links to 4 kV, Sync Selector to REPETITIVE EXT, Time Range to 50 msec, TIME SCALE to 0 and TIME BASE FREQUENCY and X SHIFT controls fully counter-clockwise. Adjust P18 (Fig. 9) to bring the right-hand end of the trace to the centre vertical graticule line. Set the X SHIFT control fully clockwise and check that the left-hand end of the trace, which should be at least 4 cm in length, is within $\frac{1}{2}$ cm of the centre line.

Switch off the power supply and change the E.H.T. links to the 2 kV setting. Switch on and return the X SHIFT control to its fully counter-clockwise position. Adjust P20 to bring the right-hand end of the trace to the centre line and, if this involves much alteration, check the E.H.T. supply. If necessary, reset and repeat this setting-up procedure for the time-base.

Triggered

Position the E.H.T. links to 2 kV, put the Sync Selector to TRIGGERED EXT, the Normal/X5 switch to X5. Set P5 to its mid-position and P24 fully counter-clockwise. Put the TIME SCALE to 0 and the TIME BASE FREQUENCY and X SHIFT control fully counter-clockwise. Adjust P19 (see Fig. 9) until the time-base ceases to free-run on any Time Range. Check that trace length, when triggered, is not less than 7 cm. In particular, check that the time-base does not free-run with the Intensity Modulation Selector in the TRIGGER BRIGHT-UP position.

Time Scale Calibration

Note: Any generator or Time Marker used for Time calibration should have a frequency accuracy of ± 1 per cent or better.

Put the E.H.T. links to 2 kV, A1 VOLTS RANGE to 30, the Sync Selector to TRIGGERED Y1, the Normal/X5 switch to NORMAL and the TIME RANGE to 50 msec. Connect an audio generator to A1 INPUT d.c. terminals, tune to 400 c/s and adjust the output to give a deflection of 4 cm. Turn the TIME BASE FREQUENCY control fully counter-clockwise and adjust TRIGGER or SYNC control until the time-base just fires consistently. Set the TIME SCALE to 0 and bring the second peak of the waveform to the centre vertical graticule line by using the X SHIFT control.

Adjust P5 (see Fig. 9) until exactly 8 cycles are obtained between 0 and 2 of the outer TIME SCALE calibration. The other ranges should be within ± 10 per cent of the data given below:

Time Range	Frequency	Cycles Displayed	Time Scale
1500 msec	2 c/s	2	0-10(inner)
500 msec	10 c/s	2	0-2 (outer)
150 msec	100 c/s	6	0-6 (inner)
15 msec	1 kc/s	6	0-6 (inner)
5 msec	2 kc/s	4	0-2 (outer)
1500 μ sec	10 kc/s	6	0-6 (inner)
500 μ sec	20 kc/s	4	0-2 (outer)
150 μ sec	100 kc/s	6	0-6 (inner)

On 1500 μ sec range, check that Normal/X5 switch gives a reduction in sweep velocity of 5:1 ± 3 per cent.

Sync Checks

Switch the Sync Selector to REPETITIVE EXT, apply a sinusoidal 10 V peak-to-peak signal to the SYNC and A2 terminals and check that the trace can be synchronized on every Time Range setting at NORMAL speed with suitable frequencies from 20 c/s upwards.

Note: The start of the trace should be negative, that is, downwards, when the TRIGGER or SYNC control is set in the negative direction.

Repeat the test with the Sync Selector on REPETITIVE Y2. Change the input to the A1 INPUT d.c., set the Sync Selector to REPETITIVE Y1 and again check synchronization of the trace. Use a 1 cm deflection in both instances. Always use 6 cycles of signal displayed on screen.

Trigger Checks

Switch the Sync Selector to TRIGGERED EXT, apply a sinusoidal 10 V peak-to-peak signal to the SYNC and A2 terminals and check that the time-base can be triggered by frequencies above 20 c/s by adjusting the TRIGGER or SYNC control. For frequencies between 2 and 20 c/s, apply a 20 V signal.

Change the Sync Selector to TRIGGERED Y2 when the time-base should operate with a 1 cm deflection for frequencies above 20 c/s and with 2 cm deflection from 2 to 20 c/s.

Repeat the last step with the generator connected to the A1 INPUT d.c. terminal and the Sync Selector at TRIGGERED Y1. Use 6 cycles of signal displayed on screen. On any range, check that the signal used to trigger at NORMAL speed also triggers at X5 speed.

Trigger Delay

Put the Sync Selector to TRIGGERED EXT, the Time Range to 150 μsec and TIME BASE FREQUENCY control fully counter-clockwise. Transpose the side-panel Y1 link to the left and connect a 470 k Ω resistor from the associated terminal to the TUBE ANODE terminal and a 1000 pF capacitor from Y1 to the SYNC terminal.

Apply a negative 1 μsec square pulse (maximum rise time 0.2 μsec) to the SYNC terminal and turn the TRIGGER or SYNC control in the -ve direction until the time-base fires consistently.

Note: The displayed pulse should have a flat top, indicating a trigger delay of less than 1 μsec .

Repeat the test with a positive pulse and SYNC or TRIGGER in the positive direction. Remove the added components and change back the Y1 link.

SETTING UP THE INTENSITY MODULATION

With the Intensity Modulation Selector positioned at OFF and an Avometer Model 8 on the 1000 V range connected between COMMON and V19 cathodes (pins 3 and 8), adjust P26 (see Fig. 9) to obtain a reading of 400 V.

With the Intensity Modulation Selector at TRIGGER BRIGHT-UP, any Time Range (X5 position), the Sync Selector in a TRIGGERED position and no input signal, carefully adjust P24 (Fig. 9) so that the spots just disappear.

Check that, when the Sync Selector is in the TRIGGERED position, the fly-back is

suppressed on all ranges, except that when using the time-base as a divider circuit, a small amount (2 cm approx.) of fly-back is allowable at the right-hand end of the trace on ranges faster than 5 msec.

Check that turning the Intensity Modulation Selector to the TRIGGER BRIGHT-UP position does not materially shorten the time-base length.

CALIBRATION VOLTAGE

To check the 50 V peak-to-peak winding of T1, connect a suitable voltmeter between the CAL and COMMON terminals.

Note: If the voltage is checked with a low-resistance meter, the reactance ($6370\ \Omega$) of the capacitor C61 ($0.5\ \mu\text{F}$) must be taken into account.

BEAM BRIGHTNESS EQUALIZER

Caution: Do not touch any part of the circuit while the power supply is connected to the instrument. When the oscillograph is switched off, two minutes, at least, must be allowed to elapse before touching any part of the wiring. Some tags of the CRT holder and terminals on the side panels carry very high potentials. Contact with such points is dangerous.

Remove the instrument case from the chassis as described on page 17.

Remove the four screws securing the aluminium casting on which the leather carrying handle is mounted, thus obtaining access to an arcuate cover in the Mumetal screen.

Remove this screen and slacken off the two clamp screws of the magnetic adjuster.

With the instrument switched on and the BRIGHTNESS control set so that the two traces are just visible, carefully slide the magnet assembly up and down the tube neck until both beams are of equal brightness. Put back the arcuate cover in the Mumetal screen and re-check the brightness.

To correct for lowered beam brightness resulting from a greater signal excursion on one beam, adjust the brightness with appropriate signals applied to the inputs of the amplifiers as already outlined. If the operating voltage of the instrument is changed from 2 kV to 4 kV or vice versa, re-check these adjustments. Alternatively, make the adjustment initially so that at either setting of the tube supply a reasonable compensation is maintained.

If the magnets are removed from their holders, care must be taken to replace them the same way round.

VOLTAGE READINGS

Voltage readings given below are useful as a guide when servicing. Some variation of the figures must be expected because of component tolerances and allowance must be made correspondingly. Readings were taken employing an Avometer Model 8, the highest range compatible with reading accuracy being used in each instance. Controls and switches were positioned as stated below.

E.H.T. links to 2 kV
 A2 SENSITIVITY 10 V/mm
 A1 Volts Range at 1000
 A1 VOLTS to 0
 Y1 SHIFT to centre the trace
 Y2 SHIFT to centre the trace
 TIME SCALE to 0
 Time Range at OFF
 Sync Selector to REPETITIVE EXT.

X SHIFT to centre the spots
 FOCUS for sharp outline
 TRIGGER OR SYNC fully counter-clockwise
 TIME BASE FREQUENCY fully counter-clockwise
 Time Range at 50 msec.
 Intensity Modulation Selector at OFF
 BRIGHTNESS fully counter-clockwise
 Normal /X5 to NORMAL

A1 AMPLIFIER

V9 Anode	pin 3	76 V					
V9 Screen	pin 4	36 V					
V9 Cathode	pin 8	0.87 V					
V10 Anode	pin 3	87 V					
V10 Screen	pin 4	19 V					
V10 Cathode	pin 8	0.23 V					
V11 Anode	pin 3	325 V					
V11 Grid	top cap	76 V					
V11 Cathode	pin 8	84 V					
V12 Anode	pin 3	330 V					
V12 } Screens V13 }	pins 2	325 V					
V12 } Cathodes V13 }	pins 6	87 V					
V13 Anode	pin 3	320 V					
Across R55	(see Fig 8)	330 V					

A1 Amplifier

Across R57	(see Fig 8)	55.8 V					
Across R58	(see Fig 8)	216 V					
Across R59	(see Fig 8)	260 V					
Across R60	(see Fig 8)	75 V					
Across R62	(see Fig 8)	15 V					
Across R63	(see Fig 8)	38 V					
Across R64-R65	(see Fig 8)	550 V					
Across R67	(see Fig 8)	335 V					
Across R68	(see Fig 8)	280 V					
Across R74	(see Fig 8)	320 V					
Across R77	(see Fig 8)	300 V					
Across R78	(see Fig 8)	57 V					
Across R79	(see Fig 8)	308 V					
Across R82	(see Fig 8)	555 V					
Across R131	(see Fig 8)	81.5 V					

A2 AMPLIFIER

V21 Anode	pin 3	322 V					
V21 Screen	pin 2	340 V					
V21 Cathode	pin 6	3.85 V					
V22 Anode	top cap	860 V					
V22 Cathode	pin 8	490 V					
Across R105	(see Fig 8)	2.5 V					
Across R127	(see Fig 8)	162 V					
Across R130	(see Fig 8)	134 V					

TIME-BASE

V5 Anode	pin 2	280 V					
V5 Cathode	pin 3	60 V					
V5 Anode	pin 5	275 V					
V5 Cathode	pin 6	12.5 V					
V6 Cathode	pin 8	483 V					
V7 Anode	pin 3	603 V					
V7 Cathode	pin 6	480 V					
V8 Anode	pin 3	482 V					
V8 Screen	pin 2	138 V					
V8 Cathode	pin 6	0 V					
Across R17	(see Fig 9)	63 V					
Across R20	(see Fig 9)	11 V					
Across R21	(see Fig 9)	46 V					
Across R70	(see Fig 9)	65 V					
Across R22	(see Fig 9)	162 V					
Across R23	(see Fig 9)	150 V					
Across R29	(see Fig 9)	3.1 V					
Across R30	(see Fig 9)	610 V					
Across R34	(see Fig 9)	36 V					
Across R35	(see Fig 9)	0 V					
Across R36	(see Fig 9)	460 V					
Across R40	(see Fig 9)	174 V					

INTENSITY MODULATION

V19 Anode	pin 1	640 V					
-----------	-------	-------	--	--	--	--	--

Intensity Modulation

V19 Cathodes	pins 3 or 8	400 V					
V19 Grid	pin 7	385 V					
V20 Anode	pin 3	330 V					
V20 Screen	pin 4	63.5 V					
V20 Cathode	pin 8	1.12 V					
Across R100–R102	(see Fig 9)	390 V					
Across R103	(see Fig 9)	245 V					
Across R104	(see Fig 9)	318 V					
Across R107	(see Fig 9)	67 V					
Across R108	(see Fig 9)	335 V					

650 V H.T. CIRCUIT

V1 Cathode	pin 8	920 V					
V3 Anode	top cap	870 V					
V3 Cathode (H.T.)	pin 8	640 V					
V4 Screen	pin 4	312 V					
V4 Grid	top cap	132 V					
V4 Cathode	pin 8	159 V					
V16 Grids	pins 2 or 7	320 V					
V16 Cathode	pin 8	340 V					
V16 Cathode	pin 3	325 V					
Across R3	(see Fig 8)	545 V					
Across R4	(see Fig 8)	263 V					
Across R9	(see Fig 8)	95 V					
Across R10	(see Fig 8)	290 V					

650 V H.T. Circuit

Across R11	(see Fig 8)	132 V					
Across R41	(see Fig 9)	295 V					
Across R43	(see Fig 9)	318 V					

2 kV or 4 kV E.H.T. CIRCUIT

V15 Anode	top cap	550 V POS*				
V14 Anode	top cap	1650 V NEG*				
FOCUS slider	1310 V-1110 V clockwise NEG*					
BRIGHTNESS slider	1575 V-1635 V clockwise NEG*					
Across R12	(see Fig 9)	315 V				
Across R89	(see Fig 9)	39 V				
Across R90	(see Fig 9)	985 V				
Across R91	(see Fig 9)	395 V				
Across R92	(see Fig 9)	465 V				
Across R95	(see Fig 9)	3.8 V				

*Electrostatic meter

POTENTIOMETERS

Y1 SHIFT slider	592 V-648 V clockwise	
Y2 SHIFT slider	138 V-650 V clockwise	
TIME BASE FREQUENCY	480 V-152 V clockwise	
A1 VOLTS end tag	Scale 0-100 650 V-600 V	
X SHIFT slider	230 V-465 V clockwise	
TIME SCALE slider (earthy)	0 V-228 V clockwise	
TIME SCALE slider	242 V-462 V clockwise	

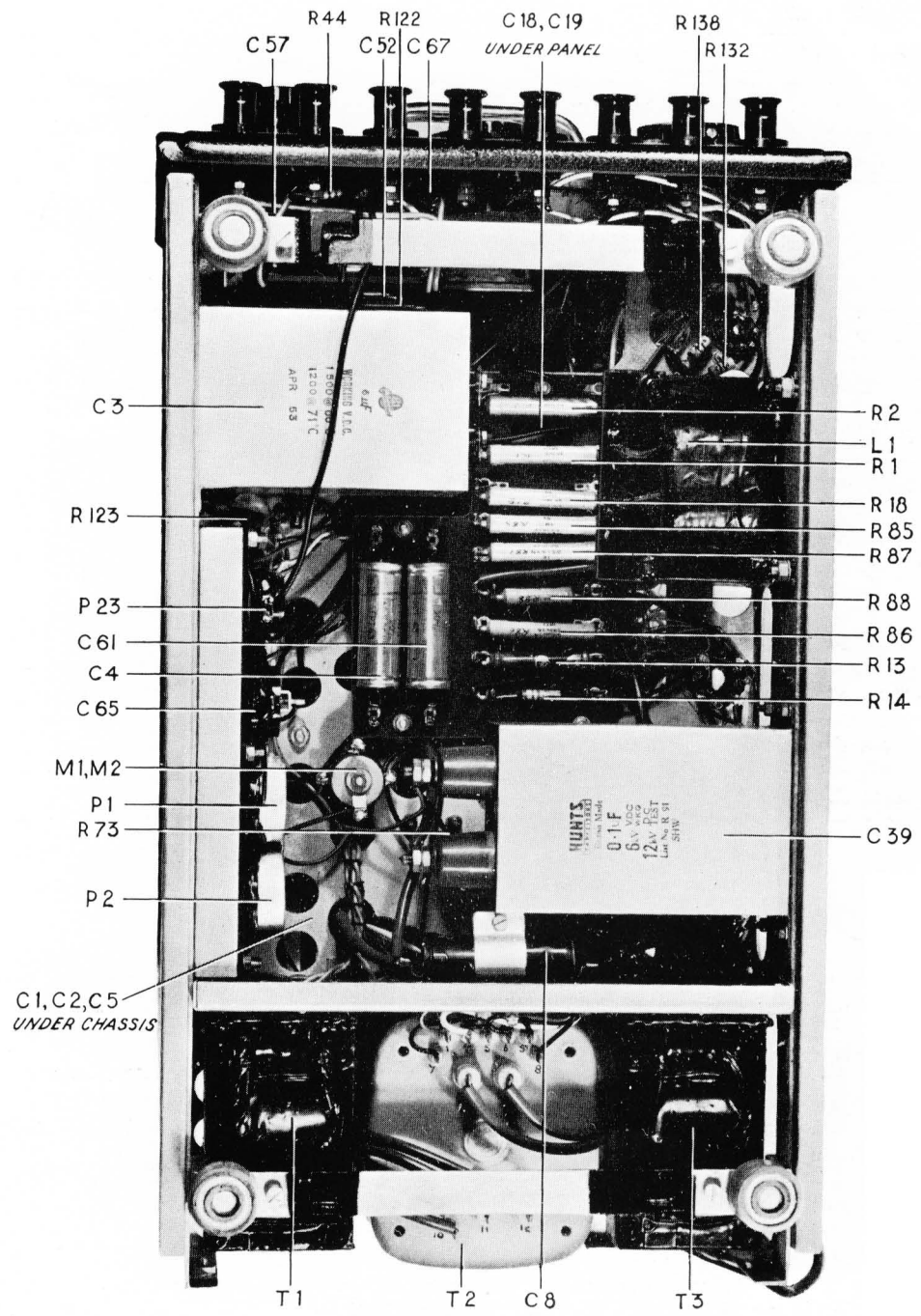

Fig. 7 Bottom View

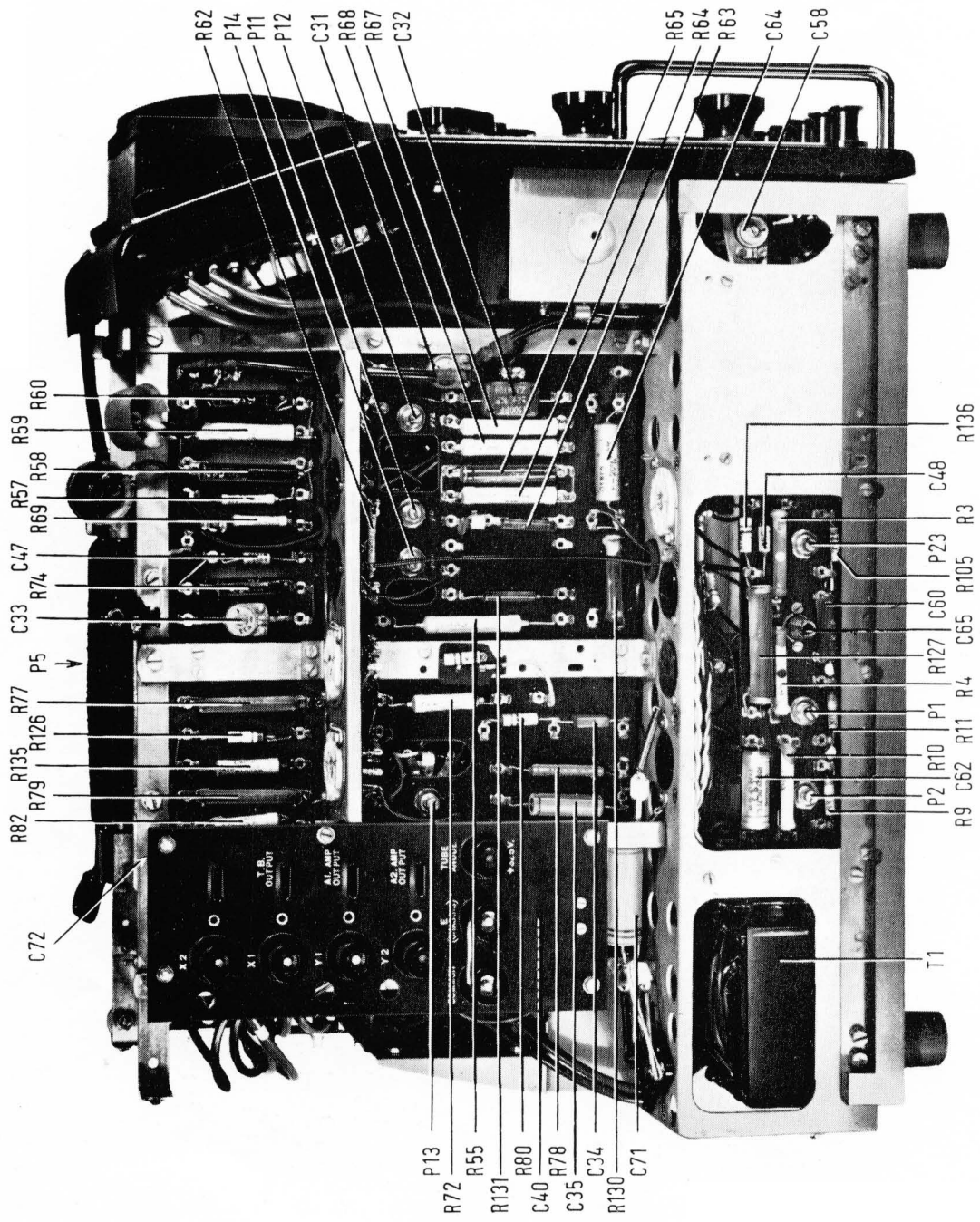

Fig. 8 Left-hand View

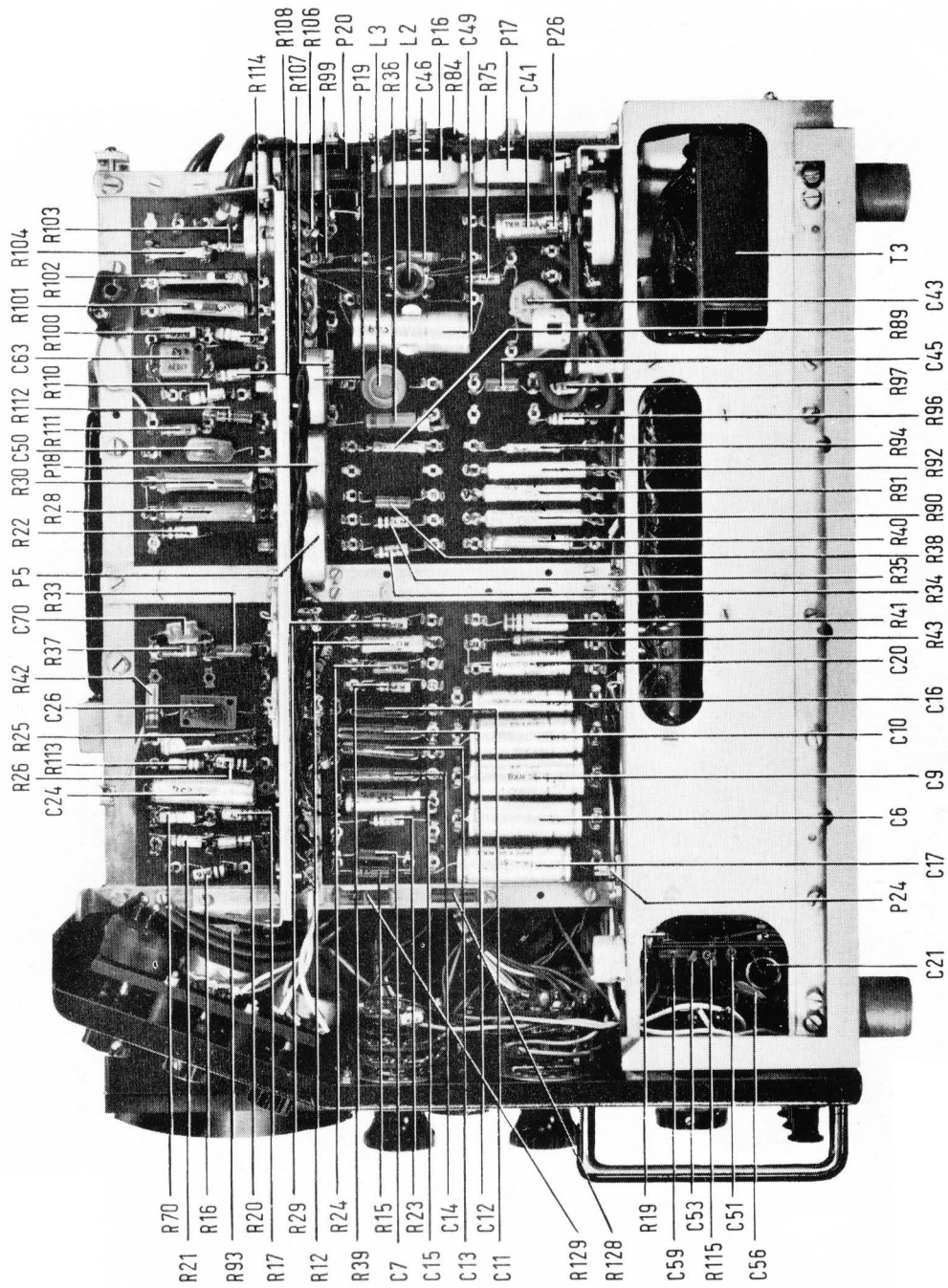

Fig. 9 Right-hand View

CIRCUIT COMPONENTS

N.B. Orders for spare parts must include the instrument serial number that is marked above the mains selector panel.

Ref.	Value	Tolerance	Rating	Part Number
R1	68 kΩ	±5%	2 W	M132510/41
R2	68 kΩ	±5%	2 W	M132510/41
R3	680 kΩ	±20%	1 W	DR02/68420
R4	4.7 MΩ	±20%	1 W	DR02/47520
R5	470 Ω	±20%	1/2 W	DR08/47120
R6	470 Ω	±20%	1/2 W	DR08/47120
R7	47 Ω	±20%	1/2 W	DR08/47020
R8	470 Ω	±20%	1/2 W	DR08/47120
R9	390 kΩ	±20%	1/2 W	DR08/39420
R10	470 kΩ	±20%	1 W	DR02/47420
R11	390 kΩ	±20%	1/2 W	DR08/39420
R12	820 kΩ	±5%	1 W	M132510/38
R13	560 kΩ	±10%	1 W	DR02/56410
R14	68 kΩ	±10%	1/2 W	DR08/68310
R15	1 MΩ	±20%	1/2 W	DR08/10520
R16	1 MΩ	±20%	1/2 W	DR08/10520
R17	27 kΩ	±10%	1/2 W	DR08/27310
R18	68 kΩ	±5%	2 W	M132510/41
R19	4.7 MΩ	±1%	1 W	M132510/98
R20	4.7 kΩ	±10%	1/2 W	DR08/47210
R21	22 kΩ	±10%	1/2 W	DR08/22310
R22	150 kΩ	±10%	1/2 W	DR08/15410
R23	150 kΩ	±10%	1/2 W	DR08/15410
R24	680 kΩ	±20%	1/2 W	DR08/68420
R25	150 kΩ	±5%	2 W	M132510/114
R26	1 MΩ	±20%	1/2 W	DR08/10520
R27	470 Ω	±20%	1/2 W	DR08/47120
R28	82 kΩ	±20%	2 W	DR01/82320
R29	4.7 kΩ	±10%	1/2 W	DR08/47210
R30	270 kΩ	±20%	2 W	DR01/27420
R31	470 Ω	±20%	1/2 W	DR08/47120
R32	1.2 MΩ	±10%	1/2 W	DR08/12510
R33	68 kΩ	±20%	1/2 W	DR08/68320
R34	220 kΩ	±20%	1/2 W	DR08/22420
R35	1.5 MΩ	±10%	1 W	DR08/15510
R36	1.2 MΩ	±5%	1 W	M132510/99
R37	390 kΩ	±10%	1/2 W	DR08/39410
R38	180 kΩ	±10%	1/2 W	DR08/18410
R39	2.2 MΩ	±20%	1/2 W	DR08/22520
R40	39 kΩ	±10%	1 W	DR02/39310
R41	1 MΩ	±2%	1/2 W	M132510/119
R42	22 kΩ	±10%	1/2 W	DR08/22310
R43	1 MΩ	±2%	1/2 W	M132510/119
R44	2.2 MΩ	±20%	1/2 W	DR08/22520
R45	560 kΩ	±2%	2 W	M132510/31

Ref.	Value	Tolerance	Rating	Part Number
R46	250 kΩ	±2%	1 W	M132510/47
R47	63 kΩ	±2%	$\frac{1}{2}$ W	M132510/118
R48	17.4 kΩ	±2%	$\frac{1}{2}$ W	M132510/117
R49	5.6 kΩ	±2%	$\frac{1}{2}$ W	M132510/22
R50	220 kΩ	±1%	1 W	M132510/97
R51	1.6 kΩ	±2%	$\frac{1}{2}$ W	M132574/32
R52	535 Ω	±2%	$\frac{1}{2}$ W	M132574/31
R53	160 Ω	±2%	$\frac{1}{2}$ W	M132574/30
R54	4.7 MΩ	±1%	1 W	M132510/98
R55	220 kΩ	±5%	2 W	M132510/110
R56	150 Ω	±20%	$\frac{1}{4}$ W	DR09/15120
R57	15 kΩ	±5%	$\frac{1}{2}$ W	M132510/52
R58	100 kΩ	±5%	2 W	M132510/104
R59	120 kΩ	±5%	2 W	M132510/105
R60	60 kΩ	±2%	1 W	M132510/106
R61	250 Ω	±2%	$\frac{1}{4}$ W	M132510/103
R62	15 kΩ	±5%	$\frac{1}{2}$ W	M132510/52
R63	30 kΩ	±5%	$\frac{1}{2}$ W	M132510/111
R64	470 kΩ	±5%	2 W	M132510/112
R65	560 kΩ	±5%	2 W	M132510/113
R66	150 Ω	±20%	$\frac{1}{4}$ W	DR09/15120
R67	150 kΩ	±5%	2 W	M132510/114
R68	120 kΩ	±5%	2 W	M132510/105
R69	9.6 kΩ	±2%	$\frac{1}{2}$ W	M132510/96
R70	39 kΩ	±10%	$\frac{1}{2}$ W	DR08/39310
R71	150 Ω	±20%	$\frac{1}{2}$ W	DR08/15120
R72	39 kΩ	±5%	1 W	M132510/116
R73	1 MΩ	±20%	2 W	DR01/10520
R74	330 kΩ	±2%	1 W	M132510/107
R75	56 kΩ	±10%	$\frac{1}{2}$ W	DR08/56310
R76	470 Ω	±20%	$\frac{1}{2}$ W	DR08/47120
R77	56 kΩ	±5%	15 W	DR43/56305
R78	5.6 kΩ	±5%	6 W	M132511/19
R79	56 kΩ	±5%	15 W	DR43/56305
R80	4.7 MΩ	±10%	$\frac{1}{2}$ W	DR08/47510
R81	470 Ω	±20%	$\frac{1}{2}$ W	DR08/47120
R82	560 kΩ	±1%	1 W	M132510/108
R83	470 Ω	±20%	$\frac{1}{2}$ W	DR08/47120
R84	470 kΩ	±5%	1 W	M132510/36
R85	1 MΩ	±5%	2 W	M132510/37
R86	1 MΩ	±5%	2 W	M132510/37
R87	1 MΩ	±5%	2 W	M132510/37
R88	820 kΩ	±5%	1 W	M132510/38
R89	56 kΩ	±5%	$\frac{1}{2}$ W	M132510/53
R90	1.8 MΩ	±5%	2 W	M132510/90

Ref.	Value	Tolerance	Rating	Part Number
R91	1.2 M Ω	$\pm 5\%$	2 W	M132510/91
R92	1.5 M Ω	$\pm 5\%$	2 W	M132510/92
R93	470 k Ω	$\pm 5\%$	$\frac{1}{2}$ W	M132510/67
R94	270 k Ω	$\pm 5\%$	$\frac{1}{2}$ W	M132510/93
R95	2.7 k Ω	$\pm 10\%$	$\frac{1}{2}$ W	DR08/27210
R96	82 k Ω	$\pm 10\%$	$\frac{1}{2}$ W	DR08/82310
R97	82 k Ω	$\pm 10\%$	$\frac{1}{2}$ W	DR08/82310
R99	100 Ω	$\pm 20\%$	$\frac{1}{4}$ W	DR09/10120
R100	330 k Ω	$\pm 10\%$	$\frac{1}{2}$ W	DR08/33410
R101	180 k Ω	$\pm 10\%$	1 W	DR02/18410
R102	180 k Ω	$\pm 10\%$	1 W	DR02/18410
R103	390 k Ω	$\pm 5\%$	$\frac{1}{4}$ W	M132510/100
R104	510 k Ω	$\pm 5\%$	$\frac{1}{2}$ W	M132510/101
R105	330 Ω	$\pm 10\%$	$\frac{1}{2}$ W	DR08/33110
R106	100 Ω	$\pm 20\%$	$\frac{1}{2}$ W	DR08/10120
R107	33 k Ω	$\pm 10\%$	$\frac{1}{2}$ W	DR08/33310
R108	270 k Ω	$\pm 10\%$	$\frac{1}{2}$ W	DR08/27410
R109	470 Ω	$\pm 20\%$	$\frac{1}{4}$ W	DR09/47120
R110	470 Ω	$\pm 20\%$	$\frac{1}{2}$ W	DR08/47120
R111	220 k Ω	$\pm 20\%$	$\frac{1}{2}$ W	DR08/22420
R112	1 M Ω	$\pm 20\%$	$\frac{1}{2}$ W	DR08/10520
R113	6.8 k Ω	$\pm 10\%$	$\frac{1}{2}$ W	DR08/68210
R114	82 k Ω	$\pm 10\%$	$\frac{1}{2}$ W	DR08/82310
R115	470 k Ω	$\pm 2\%$	$\frac{1}{2}$ W	M132510/30
R116	4.7 k Ω	$\pm 2\%$	$\frac{1}{2}$ W	M132510/21
R117	9.6 k Ω	$\pm 2\%$	$\frac{1}{2}$ W	M132510/96
R118	25 k Ω	$\pm 2\%$	$\frac{1}{2}$ W	M132510/25
R119	53 k Ω	$\pm 2\%$	$\frac{1}{2}$ W	M132510/95
R120	120 k Ω	$\pm 2\%$	$\frac{1}{2}$ W	M132510/28
R121	520 k Ω	$\pm 2\%$	$\frac{1}{2}$ W	M132510/94
R122	220 k Ω	$\pm 1\%$	1 W	M132510/97
R123	470 Ω	$\pm 20\%$	$\frac{1}{2}$ W	DR08/47120
R124	470 Ω	$\pm 20\%$	$\frac{1}{2}$ W	DR08/47120
R125	47 k Ω	$\pm 20\%$	$\frac{1}{4}$ W	DR09/47320
R126	680 k Ω	$\pm 20\%$	$\frac{1}{2}$ W	DR08/68420
R127	30 k Ω	$\pm 5\%$	15 W	DR43/30305
R128	400 k Ω	$\pm 1\%$	1 W	ITB.3500/C24/40401
R129	100 k Ω	$\pm 1\%$	$\frac{1}{4}$ W	ITB.3500/C21/10401
R130	180 k Ω	$\pm 20\%$	1 W	DR02/18420
R131	82 k Ω	$\pm 1\%$	$\frac{1}{2}$ W	M132510/115
R132	470 Ω	$\pm 20\%$	$\frac{1}{4}$ W	DR09/47120
R133	47 Ω	$\pm 20\%$	$\frac{1}{2}$ W	DR08/47020
R134	47 Ω	$\pm 20\%$	$\frac{1}{2}$ W	DR08/47020
R135	330 k Ω	$\pm 2\%$	1 W	M132510/107

Ref.	Value	Tolerance	Rating	Part Number
R136	4.7 M Ω	$\pm 10\%$	$\frac{1}{2}$ W	DR08/47510
R137	47 k Ω	$\pm 20\%$	$\frac{1}{4}$ W	DR09/47320
R138	470 Ω	$\pm 20\%$	$\frac{1}{4}$ W	DR09/47120
R139	560 k Ω	$\pm 20\%$	$\frac{1}{2}$ W	DR08/56420
C1	4 μ F	$\pm 20\%$	750 V	M129523
C2	4 μ F	$\pm 20\%$	750 V	M129523
C3	6 μ F	$\pm 20\%$	1500 V	M129527
C4	0.1 μ F	$\pm 20\%$	1000 V	M129701/14
C5	0.5 μ F	$\pm 20\%$	1000 V	M129521
C6	0.1 μ F	$\pm 20\%$	1000 V	M129701/13
C7	68 pF	$\pm 10\%$	350 V	M129580/18
C8	.01 μ F	$\pm 20\%$	4000 V	ITB.6016/3
C9	0.1 μ F	$\pm 20\%$	1000 V	M129701/13
C10	0.1 μ F	$\pm 20\%$	1000 V	M129701/13
C11	250 pF	$\pm 5\%$	500 V	M129526/4
C12	860 pF	$\pm 5\%$	500 V	M129526
C13	2700 pF	$\pm 5\%$	750 V	M129593/8
C14	9000 pF	$\pm 5\%$	750 V	M129593/3
C15	0.026 μ F	$\pm 5\%$	500 V	ISB.6031
C16	0.09 μ F	$\pm 5\%$	500 V	ISB.6032
C17	0.26 μ F	$\pm 5\%$	500 V	ISB.6033
C18	0.9 μ F	$\pm 5\%$	500 V	ISB.6034
C19	2.6 μ F	$\pm 5\%$	500 V	ISB.6035
C20	.01 μ F	$\pm 25\%$	1000 V	M129701/3
C21	0.1 μ F	$\pm 20\%$	1000 V	M129701/14
C22	27 pF	$\pm 2\%$	500 V	M129579/8
C23	62 pF	$\pm 2\%$	350 V	M129579/13
C24	0.1 μ F	$\pm 20\%$	350 V	M129701/9
C25	230 pF	$\pm 2\%$	350 V	M129580/118
C26	330 pF	$\pm 10\%$	350 V	M129580/42
C27	610 pF	$\pm 2\%$	350 V	M129580/116
C28	27 pF	$\pm 5\%$	500 V	M129579/51
C29	1400 pF	$\pm 5\%$	350 V	M129580/124
C30	1000 pF	$\pm 20\%$	350 V	M129544
C31	45 pF Trimmer		350 V	M128517
C32	1500 pF	$\pm 2\%$	350 V	M129580/114
C33	3.5–12 pF Trimmer		350 V	M128517/2
C34	27 pF	$\pm 10\%$	350 V	M129581/7
C35	0.1 μ F	$\pm 20\%$	350 V	M129620
C36	27 pF	$\pm 2\%$	500 V	M129579/8
C37	6.8 pF	$\pm \frac{1}{2}$ pF	750 V	M129579/71
C38	0.5 μ F	$\pm 20\%$	1000 V	M129521
C39	0.1 μ F	$\pm 20\%$	6000 V	M129520
C40	0.01 μ F	$\pm 20\%$	4000 V	ITB.6016/3
C41	0.1 μ F	$\pm 20\%$	350 V	M129701/10

Ref.	Value	Tolerance	Rating	Part Number
C42	27 pF	±2%	500 V	M129579/8
C43	100 pF	±20%	6000 V	M129636
C44	27 pF	±2%	500 V	M129579/8
C45	22 pF	±10%	350 V	M129580/5
C46	10 pF	±10%	350 V	M129580
C47	3.9 pF	±½ pF	500 V	M129579/63
C48	27 pF	±10%	500 V	M129581/7
C49	0.1 μF	±20%	1000 V	M129701/13
C50	120 pF	±10%	750 V	M129512/16
C51	22 pF	±½ pF	500 V	M129579/61
C52	27 pF	±2%	500 V	M129579/8
C53	2950 pF	±2%	350 V	M129580/119
C54	1420 pF	±2%	350 V	M129580/120
C55	510 pF	±2%	350 V	M129580/121
C56	210 pF	±2%	350 V	M129580/122
C57	68 pF	±2%	350 V	M129580/20
C58	45 pF Trimmer		350 V	M128517
C59	1000 pF	±5%	350 V	M129580/112
C60	1500 pF	±5%	350 V	M129580/113
C61	0.5 μF	±20%	350 V	M129701/19
C62	0.01 μF	±25%	1000 V	M129701/13
C63	470 pF	±10%	350 V	M129580/48
C64	0.01 μF	±25%	1000 V	M129701/3
C65	500–3000 pF Trimmer		250 V	M128512/3
C66	270 pF	±2%	350 V	M129580/123
C67	470 pF	±20%	1750 V	M129622/2
C68	1000 pF	±20%	500 V	M129646/9
C69	3000 pF	±20%	500 V	M129646/25
C70	27 pF	±10%	350 V	M129581/7
C71	0.5 μF	±20%	350 V	M129701/19
C72	0.01 μF	±25%	1000 V	M129701/4
C73	0.03 μF	−20% +80%	500 V	1SB.6015/2

Ref.	Value	Rating	Part Number
P1	1 MΩ	2 W	KY9988/38
P2	500 kΩ	2 W	KY9988/74
P3	250 kΩ	2 W	KY9988/18
P4	250 kΩ	2 W	KY9988/18
P5	1 MΩ	1½ W	KS92135/3
P6	50 kΩ	4 W	M158520
P7	50 kΩ	4 W	} M158522
P8	50 kΩ	4 W	
P9	15 kΩ	4 W	M158520/10
P10	15 kΩ	4 W	M158520/10
P11	500 Ω	1 W	M158526/4

Ref.	Value	Rating	Part Number
P12	30 k Ω	2 W	M158513
P13	0.5 M Ω	2 W	KY9988/74
P14	4 k Ω	1 W	M158526/6
P16	250 k Ω	2 W	KY9988/72
P17	250 k Ω	2 W	KY9988/72
P18	500 k Ω	$\frac{1}{4}$ W	KS92135/6
P19	500 k Ω	$\frac{1}{4}$ W	KS92135/6
P20	1 M Ω	2 W	KY9988/38
P21	500 k Ω	$1\frac{1}{2}$ W	M158521/11
P22	50 k Ω	2 W	KY9988
P23	500 Ω	1 W	M158526/4
P24	1 M Ω	$\frac{1}{4}$ W	IUB.8007/2
P25	500 k Ω	2 W	KY9988/22
P26	250 k Ω	$1\frac{1}{2}$ W	KS92135/7

Ref.	Description	Function	Part Number
S15 } S1 } S2 } S3 }	6-position 4-pole	Sync Selector	M154519
S4 } S5 } S6 }	11-position 3-pole	Time Range	M154508
S7 } S8 }	8-position	A1 Volts Range	MC460056
S9	On/Off 2-pole		ISB.4002
S11 } S12 }	4-position 2-pole	Intensity Modulation Selector	M154510
S13 } S14 }	7-position	A2 Sensitivity	MC460055
S16 } S17 }	2-position 2-pole	Normal X5	ISB.4002
T1	—	—	KA30285
T2	—	—	IUB.3012 (200/250 V) or IUB.3013 (105/130 V)
T3	—	—	KA30284

Ref.	Description	Rating	Part Number
L1	—	—	MC414013
L2	—	—	MC430457
L3	—	—	MC430458
F1	—	3 A	M157503/11
F2	—	3 A	M157503/11
F3	—	500 mA	M157503/15
F4	—	2 A	M157503/4
M1	Metrosil	130 V	M199573
M2	Metrosil	130 V	M199573
LP	0.3 A	6.5 V	M201505

Ref.	Type
V1	53KU
V2	53KU
V3	12E1
V4	OM6
V5	6SN7GT
V6	OM4
V7	EF50
V8	EF50
V9	OM5B
V10	OM5B
V11	OM4
V12	EF50
V13	EF50
V14	SU42
V15	EL38
V16	ECC82
V18	EB91
V19	ECC82
V20	OM5B
V21	EF50
V22	EL38
V23	CRT89J

MECHANICAL PARTS

Description	Part Number
Voltage Change Plug	M143503
Side Panel Connector Plug	M143503
Tube Voltage Interchange Plug	M143503
Terminals (Internal)	ITA.212/Black
Small Control Knob (with Indicator Dot) ...	IUB.7505/13
Large Control Knob	ISB.7504/3
Switch Knob	ITB.7503/2
Transparent Cursor	ISB.7516
Switch Pointer (Transparent)	ISB.7517
Graticule	MC416050/2
Raising Member	MC416045
Leather Carrying Handle	M199809
Rubber Feet	M164537
Pilot Bulb Holder	M164500/2
Valve Retainer for 63SPT	M408045
Valve Retainer for 53KU	M203504/2
Valve Retainer for 12EI	M203504
Tube Retainer Spacing Pin	S93022
Tube Clamp Spring	M122541
Terminals (External)	ITA.212/Maroon

Ingangs impedantie:

A₁ kanaal:

A₂ kanaal

0,3 : 1,42 mΩ

0,1 : 5 mΩ

1 : 0,56 mΩ

0,2 : 0,95 mΩ

3 : 0,47 mΩ

0,5 : 0,60 mΩ

10 : 0,44 mΩ

1,0 : 0,52 mΩ

ete ete.

2 : 0,50 mΩ

5 : 0,48 mΩ

10 : 0,48 mΩ

meetkop No 247:

bezwakking 100x

Als A₁ kanaal staat in:

NOTES 0,3 : shunten met 150 pF

1 : shunten met 220 pF

3 : shunten met 270 pF

10 : shunten met 270 pF

ete.

Ingangs impedantie van deze meetkop: 9,1 mΩ

Serie Nr. 1269. Gekoekt op 27-5-'63

ACCESSORIES

OSCILLOGRAPH TROLLEY MODEL 1050 A

This trolley enables Cossor oscillographs to be wheeled easily from one part of the Laboratory or Works to another. The oscillograph stands on the steel platform of the carriage, the angle of support assuring a comfortable viewing slant whether the operator is seated or standing.

Constructed of welded-steel and fitted with rubber-tyred swivel castors, this equipment weighs 20 lb and is finished in semi-matt black stove enamel.



OSCILLOGRAPH VISOR MODEL 1066

Designed for use with Cossor oscillographs fitted with three mounting studs, this Visor provides a simple means of examining tube displays and is particularly useful for studying fast transients.

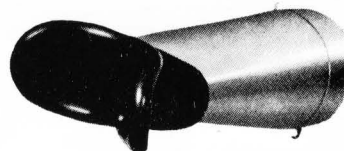

OSCILLOGRAPH CAMERA MODEL 1428 Mk II B

This Camera has been developed for use with Cossor Oscillographs, Models 1035, 1049 and 1059. It is ideal for taking single shots of a stationary waveform. Alternatively, it can be used for continuous recording of non-recurrent waveforms and slow transients by the moving-film method.

Camera Lid with End-of-film and Footage Indicator Type MC444030/2 is fitted and provides the operator with precise information of the length of recording material available. An indicating lamp lights automatically when the film or paper supply is exhausted.

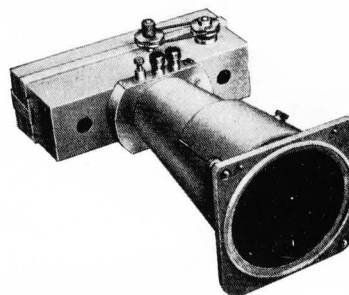

CAMERA DRIVE UNIT MODEL 1431

For use with Camera Model 1428 Mk II B, this unit comprises a powerful capacitor motor worm-coupled to a 9-speed gear-box giving film speeds of 0.05, 0.1, 0.25, 0.5, 1.0, 2.5, 5, 10 and 25 in./sec. Operation on single-phase a.c. 110 V to 250 V, 50 c/s, is through an auto-transformer which is housed with the motor capacitor.

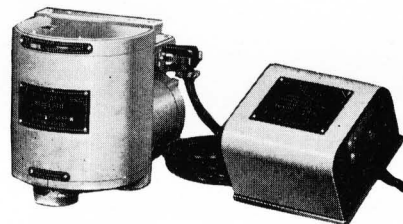

PLASTIC COVERS FOR OSCILLOGRAPHS

Plastic Cover Model 1438 fits Cossor Oscillographs Models 1035 Mk III and 1049 Mk IV. This strong P.V.C. cover protects against dust and abrasion when the instrument is not in use.

Important: Oscillographs must not be operated with the plastic covers in position as overheating of the instrument will result.

NOTE:
THIS CIRCUIT SHOWS
WIRING WHEN 200V/250V
TRANSFORMER KA30309
IS USED

CONNECTIONS OF T2
PRIMARY FOR INPUT
SUPPLIES OF 110-125V
ARE SHOWN BELOW
(PT No. KA30310)

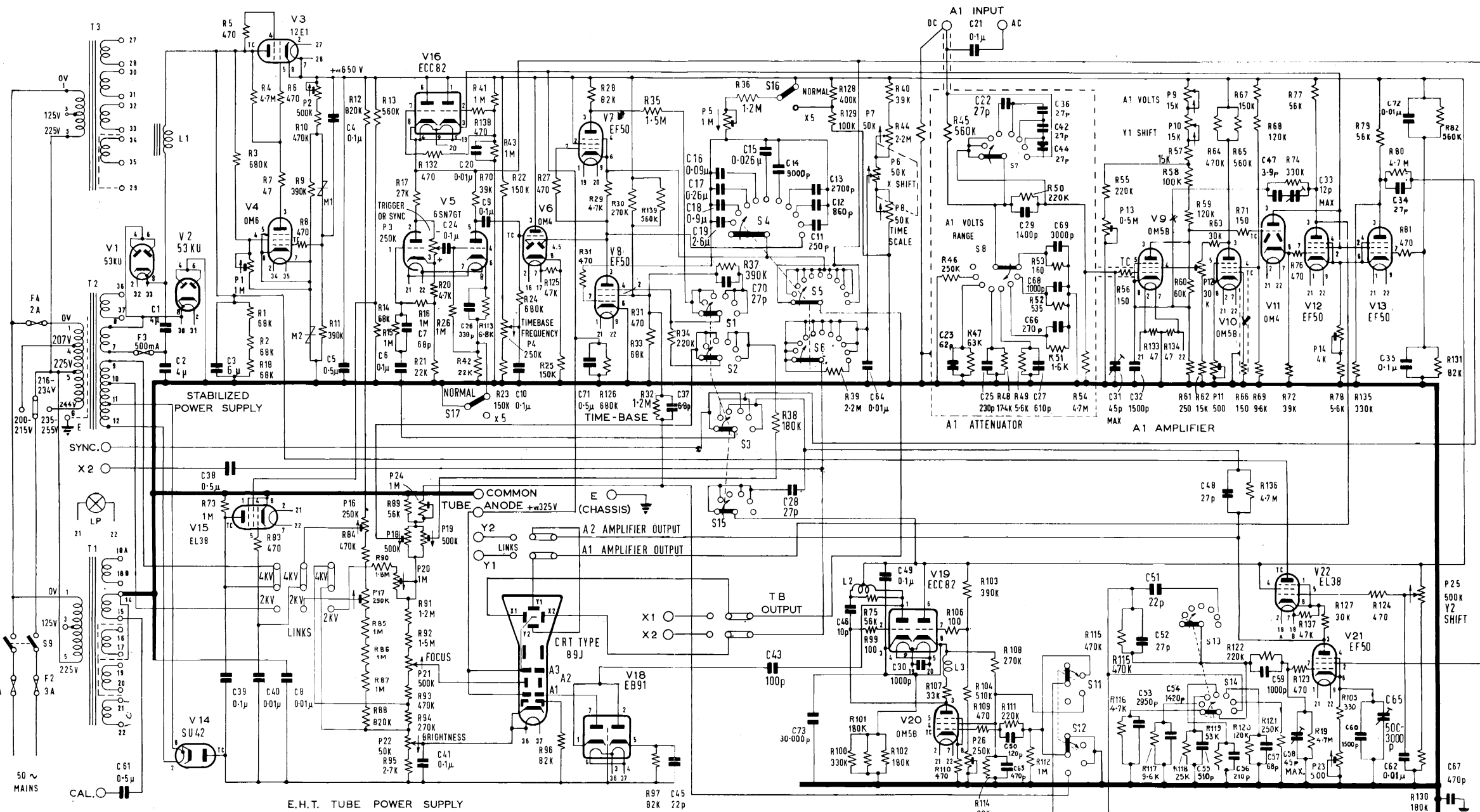
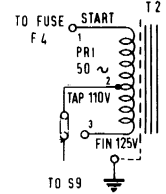

- S1 S2 S3 AND S15 GANGED SYNC SELECTOR
- S4 S5 AND S6 GANGED TIME RANGE
- S7 AND S8 GANGED A1 VOLTS RANGE
- S9 MAINS ON/OFF
- S11 AND S12 GANGED INTENSITY MOD SELECTOR
- S13 AND S14 GANGED A2 SENSITIVITY
- S16 AND S17 GANGED TIME SCALE X5

- NOTE: 1 ALL SWITCHES ARE SHOWN IN COUNTER-CLOCKWISE POSITION AS VIEWED FROM SPINDLE END
- 2 METALLIZING PINS OF 6M6 EF50 AND 6M4 VALVES TOGETHER WITH CAN CONNECTIONS ARE ALL CONNECTED TO COMMON. SCREENING CAN FOR EB91 IS NOT CONNECTED
- 3 A1 ATTENUATOR SCREEN IS CONNECTED TO COMMON NOT 'E' (CHASSIS).
- 4 CHASSIS MUST CONNECT TO COMMON OR CRT ANODE BY SIDE TERMINAL PANEL ONLY.

COSSOR OSCILLOGRAPH Model 1049 Mk IV — CIRCUIT DIAGRAM

SPARES AND SERVICE

To assure the prompt dispatch of spare parts, it is essential that the order includes the model number and serial number of the instrument, the description of the part(s), the part number(s) and the quantity required.

Whilst every effort is made by the Cossor Instrument Service Department to maintain an adequate supply of spares, a delay in dispatch must be tolerated, usually, on those parts not expected to require replacement.

Where purchase of the instrument has been made through a Cossor Stockist or Agent, all service enquiries and orders must be routed direct to that supplier.

Purchasers of instruments direct from Cossor Instruments Limited are asked to address their enquiries and orders to:

**Cossor Instruments Limited,
Cossor House,
Highbury Grove,
London, N.5.**

adding ENGLAND to this address if the purchaser is writing from outside the United Kingdom.

COSSOR INSTRUMENTS LIMITED

*The Instrument Company of the Cossor Group;
a subsidiary of the Raytheon Company, U.S.A.*

COSSOR HOUSE · HIGHBURY GROVE · LONDON, N.5 · ENGLAND

Telephone : CANonbury 1234 (15 lines)
Telegrams : Cossor, Norphone, London

Cables : Cossor, London, N.5
Codes : " Bentley's Second "